

SGAT80
SGAT100

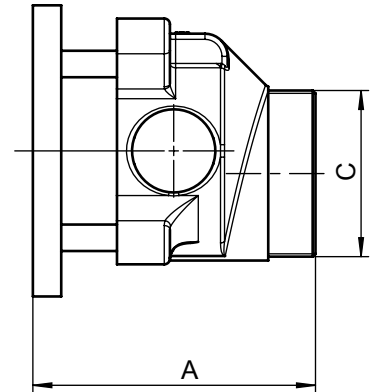

SGAT80G
SGAT100G

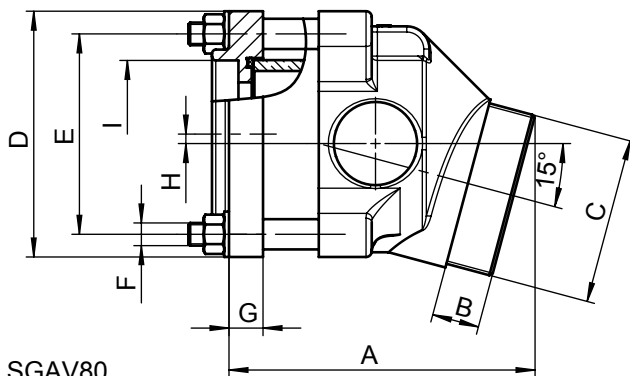
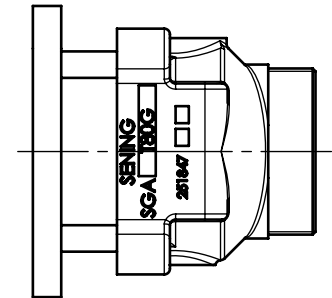

SGAV80
SGAV100

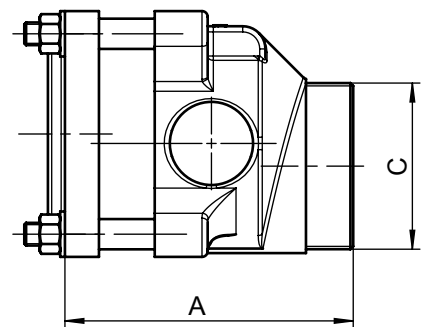

SGAV80G
SGAV100G

Werkstoffe: Aluminium
Borosilicatglas
NBR
Stahl

Material: Aluminium
Borosilicatglass
NBR
Steel

SGAV100G	163	25	G3"	□130	□106	M12	18	5	Ø111	2,35 kg
SGAV80G	163	25	G3"	□130	□106	M12	18	5	Ø91	2,40 kg
SGAV100	163	25	G3"	□130	□106	M12	18	5	Ø111	2,35 kg
SGAV80	163	25	G3"	□130	□106	M12	18	5	Ø91	2,40 kg
SGAT100G	149,5	25	G3"	Ø174	Ø150	Ø14	15	10	--	2,50 kg
SGAT80G	149,5	25	G3"	Ø154	Ø130	Ø11,5	15	0	--	2,30 kg
SGAT100	160	25	G3"	Ø174	Ø150	Ø14	15	10	--	2,50 kg
SGAT80	160	25	G3"	Ø154	Ø130	Ø11,5	15	0	--	2,30 kg
Teile-Nr./ Part-No.	A	B	C	D	E	F	G	H	I	Gewicht Weight

Schauglas-Auslaufstutzen
Sightglass - outlet connection

FMC Technologies

F.A. Sening GmbH
D-25474 Ellerbek, Germany

Weight:
kg

Date:
18.01.2011

Name:
Larsen

Part-No. SGA...

Changed:
ECN No. Date Name

06.07.11 RL;

Drawing No.:

53.251876 Bl.1

Rev.:

A

SGAT80
 SGAT100
 SGAT80G
 SGAT100G

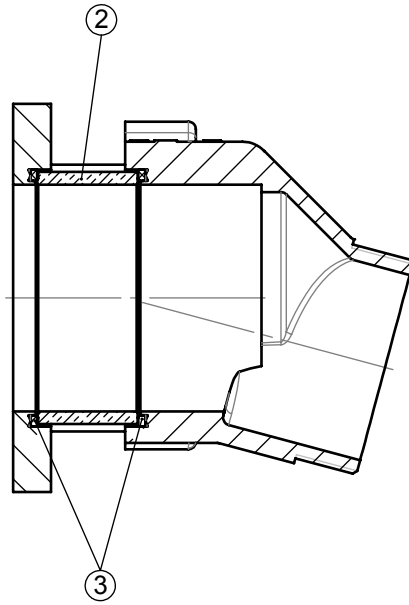

SGAV80
 SGAV100
 SGAV80G
 SGAV100G

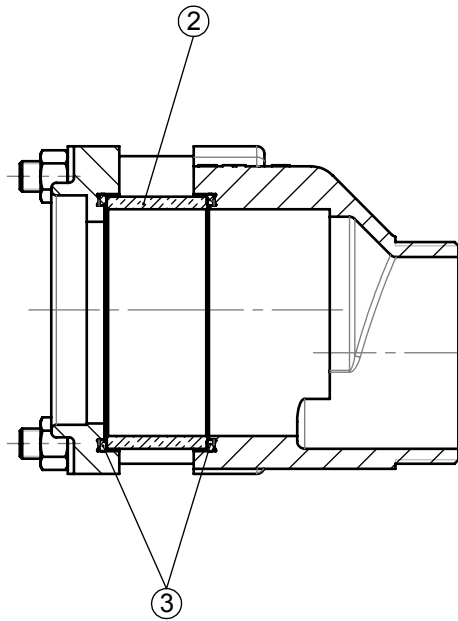

3	6000317	2	O-Ring Ø93x4 NBR	<i>O-Ring Ø93x4 NBR</i>
2	251861	1	Glaszylinder	<i>Sightglass cylinder</i>
Pos./ Item	Teile-Nr./ Part-No.	Stück/ Quant.	Benennung	<i>Description</i>

Schauglas-Auslaufstutzen
Sightglass - outlet connection

FMC Technologies F.A. Sening GmbH
 D-25474 Ellerbek, Germany

Weight: kg Date: 18.01.2011 Name: Larsen

Part-No. SGA...

Changed: ECN No. 21378 Date: 24.05.11 Name: RL; Drawing No.: 73.251876 Bl.1 Rev.: A