

FMC Technologies *Compensator, Automatic Temperature, ATC*

Parts List

Issue/Rev. 0.0 (5/13)

Bulletin PO01029

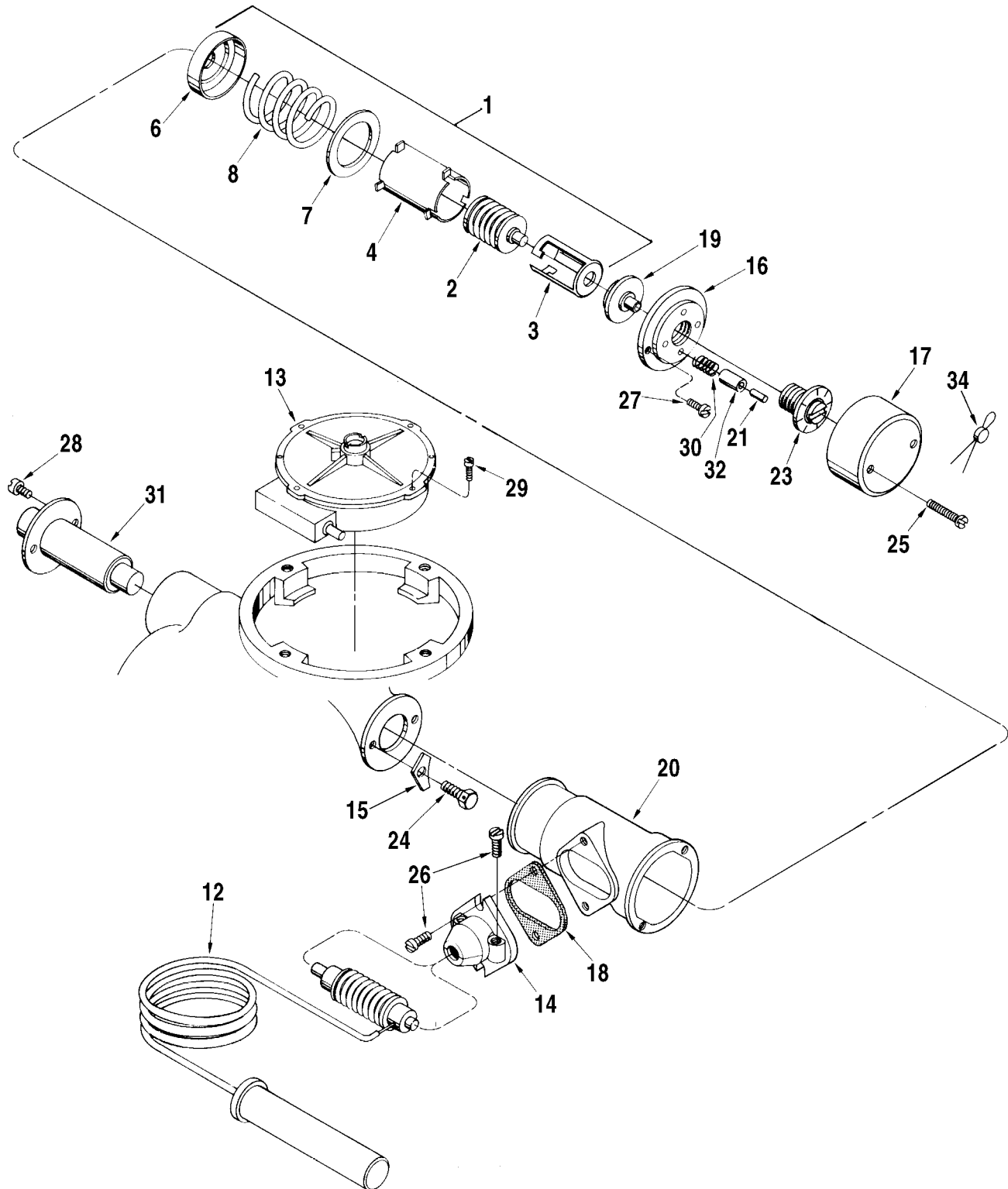

Previous Design

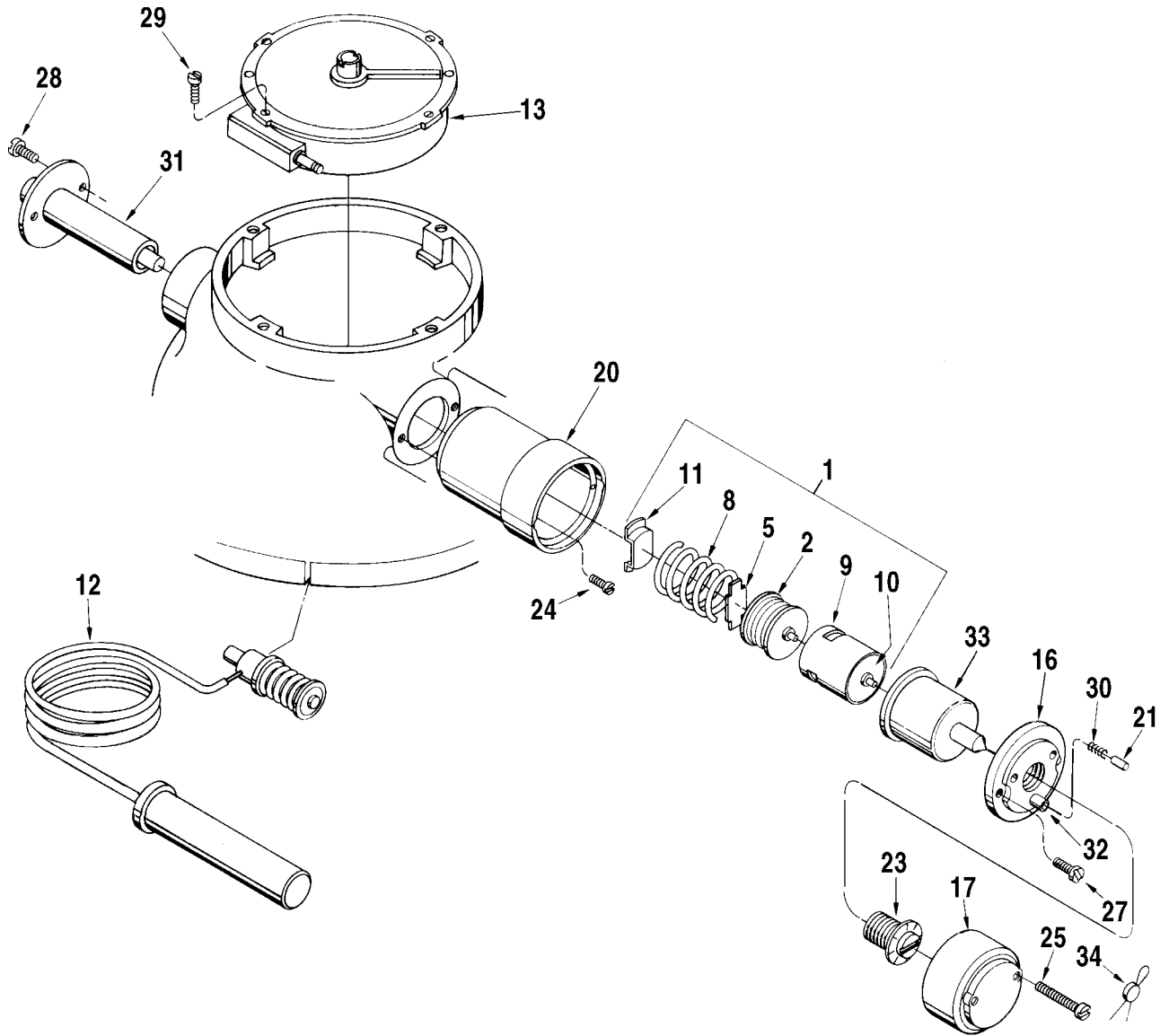

Temperature Wells

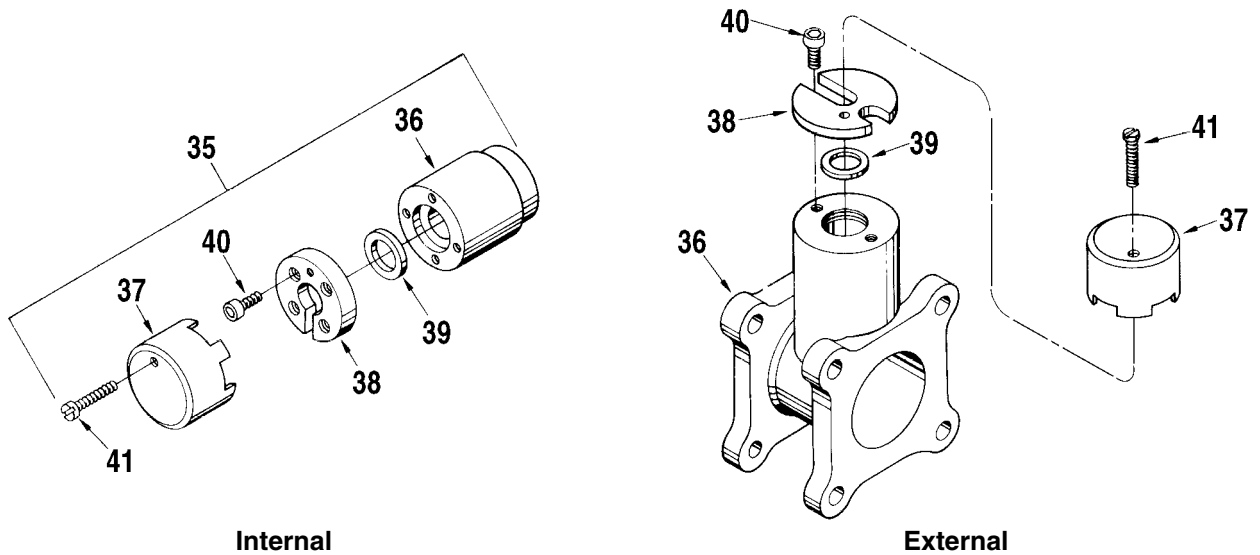

Item	Description	Qty.	Current Design*	Previous Design
1	@1 Bellows Assembly, Temperature Compensating	1	See Note	See Note
2	@1 Bellows, Compensating	1	See Note	See Note
3	Housing, Inner	1	516683-001
4	Housing, Outer	1	516915-001
5	Plate, Spring Bearing	1	010839-001
6	Retainer, Bellows	1	516913-001
7	Ring, Guide	1	516907-001
8	Spring	1	516916-001	010840-001
9	Tube, Inner	1	010848-001
10	Washer, Inner Tube	1	010850-001
11	Yoke, Spring Thrust	1	010847-001
12	@1 Bulb and Bellows	1	See Note	See Note
13	@2 Calibrator	1	See Note	See Note
14	Clamp, Half	2	506454-002
15	Clamp, Housing	2	506450-001
16	Cover	1	506160-001	506160-001
17	Cover, Knob	1	003553-001	003553-001
18	+ Gasket	1	511037-001
19	Guide	1	516910-001
20	Housing	1	518951-001	518742-001
21	Pin, Detent Plunger	1	010858-001	010858-001
22	* Pin	2	010859-001
23	Screw, Adjusting	1	009327-001	009327-001
24	Screw, #10-32 x 1/2", Drilled	2	642038-407	642038-407
25	Screw, #10-32 x 1-1/8", Drilled	2	642010-401	006729-003
26	Screw, #10-32 x 1/2"	4	015170-400
27	Screw, #8-32 x 1/2"	2	006083-002	006083-002
28	Screw, #10-32 x 3/8"	2	006045-002	006045-002
29	@3 Screw	2	See Note	See Note
30	Spring, Knob	1	003557-001	003557-001
31	Spring, Loading	1	537876-001	537876-001
32	Tube, Detent Spring	1	010857-001	010857-001
33	Tube, Outer	1	009330-001
34	+ Wire and Lead Seal	1	001627-400	001627-400

Temperature Wells

Internal

External

35	Complete Assembly, Temperature Well	1	515618-001
36	Body:			
	T-6	1	515119-001
	T-10, T-11 (Illustrated)	1	515120-001
	T-15, T-20	1	515121-001
	Internal	1	504078-002
37	Cover	1	514522-001	514522-001
38	Collar	1	012001-001	514521-001
39	+ Gasket	1	060341-001	060341-001
40	Screw:			
	Internal (5/16-18 x 3/4")	4	006409-002
	External (5/16-18 x 1")	2	060133-002
41	Screw, #10-32 x 1-5/8"	1	006479-002	006479-002

+ Recommended stock.

* Not illustrated.

@1 For part number and ordering procedure, see Form No. PO01030.

@2 For basic part number or component parts, see Form No. PO01017 and PO01028.

@3 For correct part number, refer to parts list of meter the ATC is being used on.

Publication PO01029 has replaced P0207.01X which has been made obsolete. (5/2013)

The specifications contained herein are subject to change without notice and any user of said specifications should verify from the manufacturer that the specifications are currently in effect. Otherwise, the manufacturer assumes no responsibility for the use of specifications which may have been changed and are no longer in effect.

Contact information is subject to change. For the most current contact information, visit our website at www.fmctechnologies.com/measurementsolutions and click on the "Contact Us" link in the left-hand column.

Headquarters:

500 North Sam Houston Parkway West, Suite 100, Houston, TX 77067 USA, Phone: +1 (281) 260 2190, Fax: +1 (281) 260 2191

Measurement Products and Equipment:

Erie, PA USA +1 (814) 898 5000
Ellerbek, Germany +49 (4101) 3040
Barcelona, Spain +34 (93) 201 0989
Beijing, China +86 (10) 6500 2251
Burnham, England +44 (1628) 603205

Dubai, United Arab Emirates +971 (4) 883 0303
Los Angeles, CA USA +1 (310) 328 1236
Melbourne, Australia +61 (3) 9807 2818
Moscow, Russia +7 (495) 5648705
Singapore +65 6861 3011

Integrated Measurement Systems:

Corpus Christi, TX USA +1 (361) 289 3400
Kongsberg, Norway +47 (32) 286700
Dubai, United Arab Emirates +971 (4) 883 0303

Visit our website at www.fmctechnologies.com/measurementsolutions