

2" Model SC-13

Bulletin SS01005 Issue/Rev. 1.1 (9/17)

Smith Meter® PD Meters

The **Smith Meter® Model SC-13 Meter** is a 2", single-case, straight-through type, rotary vane, positive displacement meter. Applications include: blending, batching, dispensing, inventory control, and custody transfer of oils, solvents, chemicals, paints, fats, and fertilizers.



Features

- **Superior Accuracy** – Since the unrestricted flow path results in minimal pressure drop across the measuring chamber, slippage through meter clearances is minimized and accuracy maximized.
- **Low Pressure Drop** – Low velocities and streamlined flow path provides the lowest pressure drop PD meter in the industry.
- **Positive and Accurate Registration** – High torque drive calibrator ensures accurate registration and adjustment in 0.05% increments.
- **Long Service Life** – Low friction ball bearings, fixed cam-type timing, and rugged construction give sustained accuracy and long service life.
- **Extended Flow Turndown** – NCWM approved for use from 3 to 150 GPM; an ideal solution or biofuel blending (see NTEP Certificate 95-054A4).

Operating Specifications

Maximum Flow Rate

	USGPM	L/min
Continuous Rating – Standard Trim	125	475
Intermittent Rating¹ – Standard Trim	150	570
Continuous/Intermittent Rating – All Iron	100	375

Minimum Flow Rate – Typical Performance

Linearity ²	Units	Viscosity (Centipoise – mPa·s)					
		0.5	1	5	20	100	400
±0.15%	USGPM	25	15	6	1.5	0.30	0.08
	L/min	95	57	23	6.0	1.00	0.30
±0.25%	USGPM	17	10	4	1.0	0.20	0.05
	L/min	65	38	15	4.0	0.75	0.20
±0.50%	USGPM	13	8	3	0.8	0.16	0.04
	L/min	50	30	11	3.0	0.60	0.15

Repeatability

±0.02%

Viscosity

Standard: 400 cP (2,000 SSU) maximum.

Optional: 2,000 cP (10,000 SSU) maximum – specify “High Viscosity Meter Clearances.”

Over 2,000 cP: Specify “High Viscosity Meter Clearances” and derate maximum flow rate in direct proportion to viscosity over 2,000 cP (e.g., at 4,000 cP, derate maximum flow rate to 50% of normal continuous rating - 63 USGPM).

¹ Intermittent rating applies to service on clean, refined products where continuous operation is not required (e.g., truck loading, rail loading, and other loading or batching applications).

² Based on a maximum flow rate of 125 USGPM (475 L/min).

Temperature

Standard Meter Clearances with:	
Buna:	-20°F to 150°F (-29°C to 65°C)
Viton:	10°F to 150°F (-12°C to 65°C)
PTFE ³ :	-20°F to 150°F (-29°C to 65°C)
Optional (High Temperature Meter Clearances or All Iron Trim) with:	
Buna:	-20°F to 200°F (-29°C to 93°C)
Viton:	10°F to 200°F (-12°C to 93°C)
PTFE ³ :	-20°F to 200°F (-29°C to 93°C)

For other temperatures, consult factory.

Maximum Working Pressure

Standard: 150 psig (1,034 kPa) up to 200°F (93°C).

Meter Gearing

Five U.S. Gallons or one Dekaliter per revolution of meter calibrator output shaft.

Pressure Drop (ΔP)

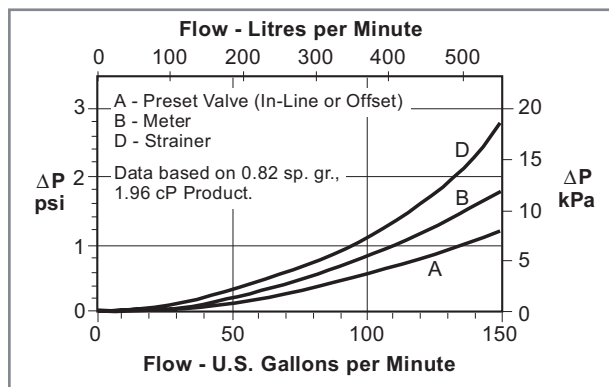

Materials of Construction

Trim	Housing	Internals	Seals ⁶
Standard	Ductile Iron	Iron, Steel, Stainless Steel, Aluminum	Cover O-Ring Std. - Buna-N Opt'l. - Viton
All Iron	Ductile	Iron, Steel, Stainless Steel	Packing Gland Std. - Buna Opt'l. - Viton or PTFE ³
Strainers	Steel	Steel, Stainless Steel	
Preset Valves	Ductile Iron	Steel, Iron, Ni-Resist	Std. - Buna-N Opt'l. - Viton or PTFE ³

³ Polytetrafluoroethylene (PTFE).

Installation

It is recommended that the meter be protected with a 40 mesh strainer.

Dimensions

Inches (Millimeters)

Note: Dimensions – inches to the nearest tenth (millimeters to the nearest whole mm), each independently dimensioned from respective engineering drawings.

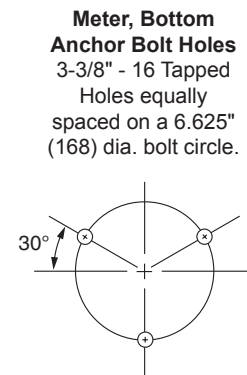
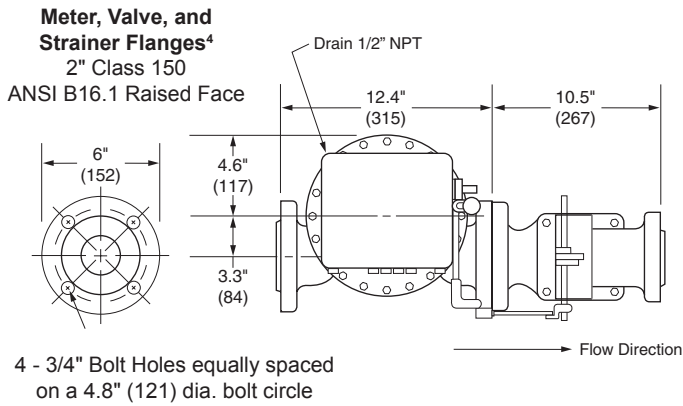

Top View

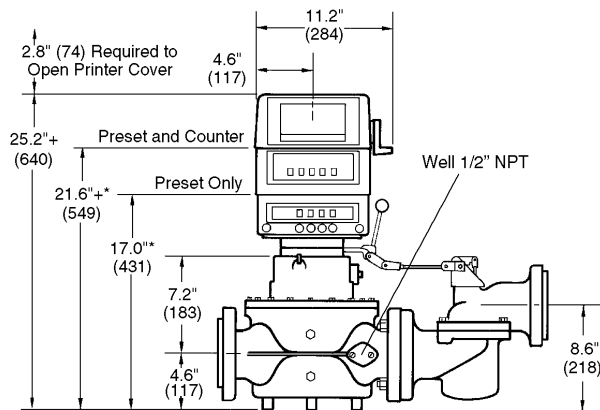

*Includes Cover.

+Deduct 3.7" (94) if Preset Counter is not required.

	Lb	Kg
Meter	97	44
2" Strainer Model 22-E3	25	11
Meter/LNC+	112	51
Preset Package+*	168	76

+ Add 10 lb. (4.5 kg) if ticket printer is required.

* Includes Meter, LNC, Preset Counter and Valve.

4 Raised face flange is standard for ductile iron meter housing. Flat faced is optional and must be specified if it will mate with cast iron components.

Ordering Information

Application	Batching, Loading, Blending, Inventory, Process Control, etc.
Operating Conditions	Liquid – Name and sp. gr., Flow Range ⁵ , Temp. Range ⁵ , Viscosity Range ⁵ , Maximum Working Pressure.
Seals	Meter: Buna ⁶ Viton or PTFE ³ . Valve: Buna ⁶ , Viton or PTFE ³ .
Units of Registration	Gallons, Litres, Pounds, Kilograms.
Direction of Flow	Left to right flow (as viewed from above) is standard and will be supplied unless right to left flow is specified.
Options and Accessories	As required.

Accessories

Strainer

2" in-line strainer with basket, Class 150 ANSI raised face flanges⁴.

Mechanical Preset Valves

2" offset-type, ductile iron, Class 150 ANSI raised face flanges.

Automatic Temperature Compensation

Model ATC – Factory-set for a given product.

Model ATG – Field-adjustable for different products.

Counters

200 Series – Accumulative, 9-digit, non-reset type.

600 Series – 5 large-digit reset, 8 small-digit non-reset.

Printer

Seven-digit accumulative.

Optional 6-digit zero start.

RTD

TP-W4-1.5 (Smith Meter[®] Temperature Probe).

Preset Counter

300C Series – 5-digit mechanical pushbutton preset with microswitch package for valve or pump control.

Pulse Transmitters

LNC Pulse Transmitter (adapts to 600 Series Counters).

Low-Resolution – 1 or 10 pulses⁷.

High-Resolution (HR) – 50 or 100 pulses⁷.

UPT – Universal Pulse Transmitter – High resolution dual pulse quadrature output in a weather-tight explosion-proof enclosure (up to 1,000 pulses/rev.).

Flow Rate Indicator

Direct mount mechanical.

Remote electronic.

Remote Registration

Electromechanical counters.

Electronic totalizers.

3 Polytetrafluoroethylene (PTFE).

4 Raised face flange is standard for ductile iron meter housing. Flat-Faced is optional and must be specified if it will mate with cast iron components.

5 Specify: minimum/normal/maximum.

6 Standard seals supplied unless optional material specified.

7 Per revolution of LNC right-hand wheel.

The specifications contained herein are subject to change without notice and any user of said specifications should verify from the manufacturer that the specifications are currently in effect. Otherwise, the manufacturer assumes no responsibility for the use of specifications which may have been changed and are no longer in effect.

Contact information is subject to change. For the most current contact information, visit our website at www.fmctechnologies.com/measurementsolutions and click on the "Contact Us" link in the left-hand column.