

ATC Automatic Temperature Compensator

Bulletin SS01038 Issue/Rev. 0.1 (4/18)

A characteristic of all liquids is that a change in volume occurs with a change in temperature. This thermal coefficient of expansion varies with each liquid. The measurement of most liquids is based on net volume, defined as volume at a referenced base temperature (60 degrees F for the petroleum industry in the U.S.A. for example). When metering liquids, the operating temperature is usually other than the base temperature and can also vary during the measurement. The difference between gross metered volume and net volume will depend on the coefficient of expansion of the liquid and the difference between average metered liquid temperature and base temperature.

Meters equipped with the **ATC Automatic Temperature Compensator** provide net volume or weight registration. This registration is based on continuous integration of gross metered volume and temperature regardless of flow rate and temperature fluctuations. It is also based on the coefficient of expansion of the particular liquid being metered.

The ATC is designed and manufactured not only as a precision instrument but also to withstand the ambient conditions of sand, dust, humidity, and temperature extremes normally encountered. The ATC can be checked in the laboratory with precision thermometers assuring high accuracy in actual field use.

Features

The ATC Temperature Compensator is simple, yet accurate and rugged. Compensation can be provided for liquids with coefficients of expansion as low as $.0003/^{\circ}\text{F}$ up to $.0020/^{\circ}\text{F}$, and for temperatures ranging from -50°F to 525°F . Assemblies are available to provide both gross and net volume or weight registration.

The temperature bulb (without well) is installed in the meter housing (or adapter) so that it is exposed directly to the metered fluid, providing the fastest possible response to temperature changes. Bulb response is not affected by



metered liquid pressure changes. Bellows movement of the standard thermal system is $.002"$ per degree Fahrenheit bulb temperature change which assures a high degree of resolution in converting temperature change to linear motion.

In addition to correcting for temperature changes, the unit also provides a means for adjustment of registration.

Meter ATC

Automatic temperature compensation is normally supplied as part of a meter assembly. Most meters have an integral temperature well to accept the bulb of the thermal system. "T" meters are provided with an external temperature well that adapts between meter and air eliminator or inlet/outlet flange. In addition to providing temperature compensation, the ATC calibrator also serves as the means for manual adjustment. ATC does not affect nominal meter dimensions except in the case of "T" meters. If special gearing is required for temperature ranges outside the limits shown by line A-A' in Figure 4, meter gearing would be affected.

Dual Head Adapter ATC

The dual head adapter provides both net and gross registration and can be adapted to any meter. Gross meter registration is adjusted using the meter calibrator. The rigid extension of the dual head serves as a straight-through drive from the gross meter output to gross register or accessories. The extension length should be specified based on height necessary to clear the net accessories. From the standpoint of mechanical limitation, the dual head ATC has 1% greater maximum temperature range than meter ATC. Mechanical range and limitations are indicated by lines A-A," Figure 4.



Single Head Adapter ATC

The single head adapter allows gross and net registration with a single stack of accessories. The single head adapter is applicable to any Smith Meter® accessory. If mounted on a Large Numeral Counter, Adapter Kit 519288-001 is also necessary.

As with the dual head adapter, the single head adapter also has 1% greater maximum temperature range than meter ATC. Mechanical range and limitations are indicated by lines A-A", Figure 4.

If special gearing is required for temperature ranges outside of these limits, gearing in the single head adapter would be affected.

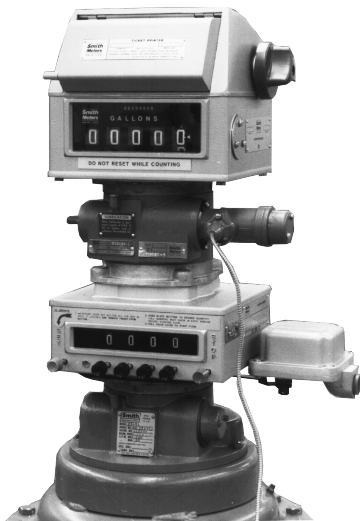

Ventilated Extension with ATC

Where metered liquid temperatures exceed 300°F, the thermal system and calibrator should be removed from the heat generated by the meter case. The meter is fitted with a dummy calibrator as part of the kit. A ventilated extension which dissipates heat can be mounted as illustrated or with a dual head adapter (not illustrated). Required capillary length must be specified (60" maximum).

Principle of Operation

The ATC consists of:

1. thermal system
2. calibrator system

The thermal system consists of a bulb and bellows assembly and an ambient bellows assembly. See Figure 1. The bulb is immersed in the metered liquid so that temperature changes of the liquid cause a change in volume of the bulb-filled liquid. This volume change is transmitted through the capillary tube to the product bellows providing linear movement of the bellows in response to bulb temperature change. Both the product bellows and ambient bellows increase in length with an increase in ambient temperature. Design is such that an increase in ambient bellows length causes a decrease in length of the complete

ambient bellows assembly. This, then, compensates for changes in length of the product bellows, and other components in the unit, due to ambient temperature changes. The calibrator integrates gross volume from both the calibrator input revolution and linear movement produced by the thermal system to provide net volume in the form of calibrator output revolutions. The calibrator utilizes two overriding clutches and an eccentric. A change in the amount of eccentricity varies the drive ratio between the calibrator input shaft and output shaft. The thermal system movement positions the calibrator plunger, which in turn positions the eccentric arm. An increase in temperature results in less eccentricity and reduced registration. A decrease in temperature causes greater eccentricity which increases registration. For a detailed explanation of calibrator operation see Bulletin [SS01030](#).

Thermal system movement is strictly dependent on temperature change and is independent of the metered liquids' coefficient of expansion. Since the coefficients of expansion of the various liquids vary widely, the eccentric arm fulcrum pin is positioned to change the amount of calibrator correction with respect to thermal system movement. Figure 2 shows fulcrum pin location for 18° API temperature compensation. This relatively low coefficient of expansion (.00039/°F) requires a rather high degree of

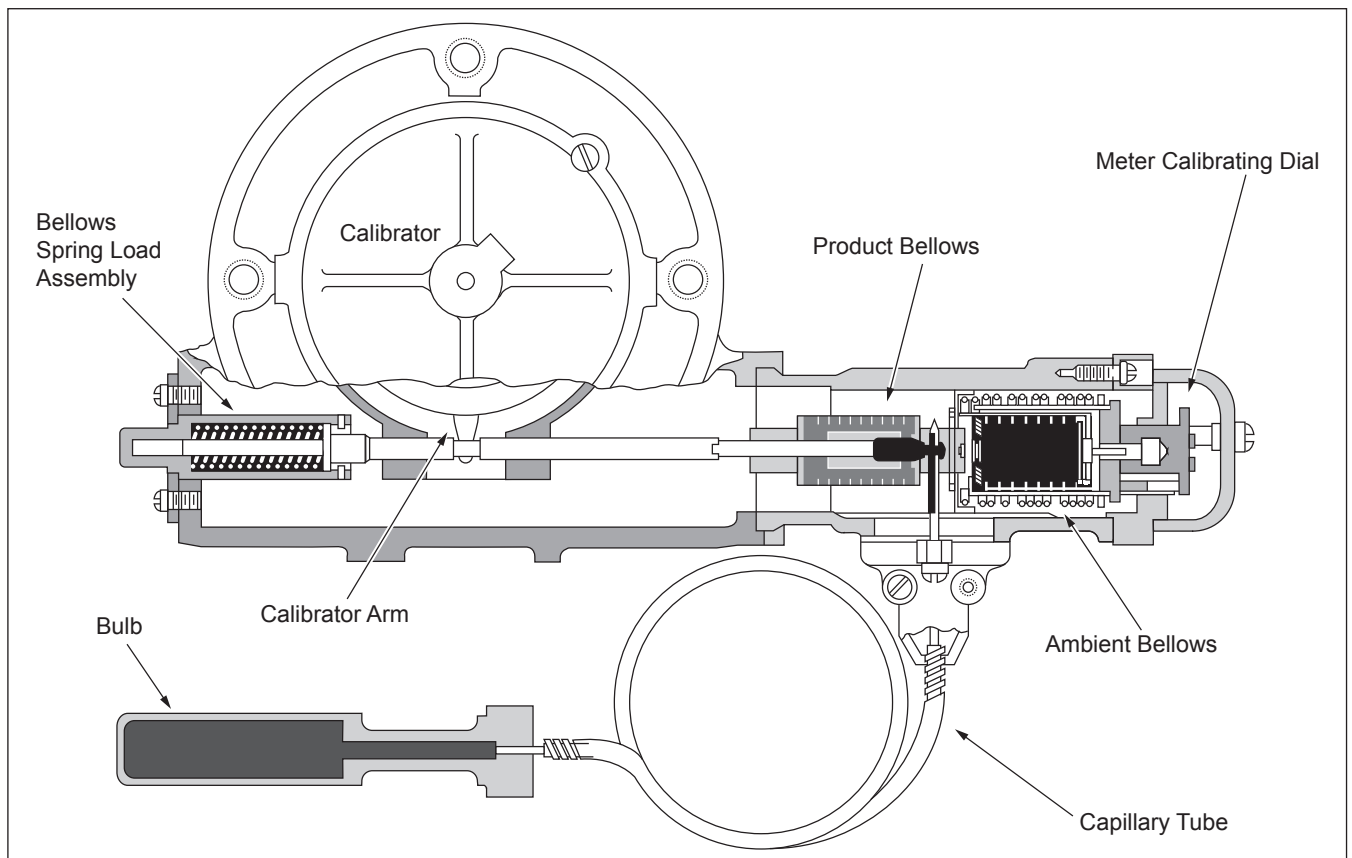

Figure 1

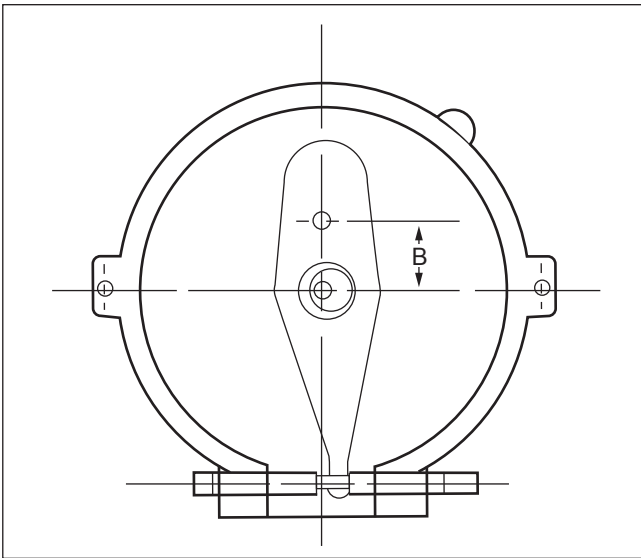

Figure 2

thermal system and plunger movement to effect a nominal change in eccentricity and calibrator correction. Figure 3 shows fulcrum pin location for .580 specific gravity temperature compensation. This relatively high coefficient of expansion (.0011/°F) requires little thermal system and plunger movement to effect a rather high change in eccentricity and calibrator correction.

Temperature Range

Temperature range limits are determined by two factors: the thermal system and the amount of mechanical correction in the calibrator. The thermal system range is 100°F, 150°F, or 200°F, depending on maximum operating temperature (see Performance Characteristics). The total mechanical correction used is 8.5%. Figure 4 illustrates the temperature range for standard units. Curves A-A' and A-A" define the mechanical correction limits for meter and single head/dual head calibrators respectively. B and B' define the thermal system limits. A-A' and A-A" may be shifted up or down by providing special gearing in the meter, dual head adapter, or single head adapter. B-B' may be shifted up or down by providing special bulb filling for the thermal system (see Performance Characteristics).

Performance Characteristics

Correction Range

API Gravities: 0°F to 150°F.

Specific gravity at 60/60°F or 15/15°C: 1.075 to .500.

Coefficient of Expansion: .0003/°F to .0017/°F, or .0005/°C to .003/°C.

Temperature Range

See Figure 4.

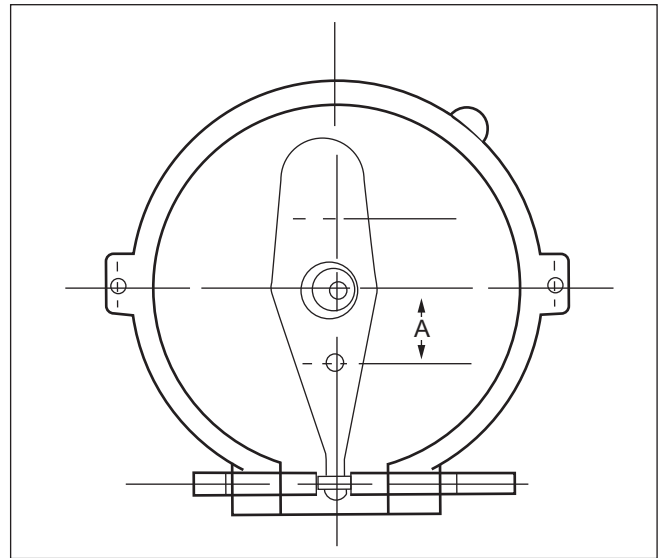

Figure 3

Thermal System

Standard: 0°F to 150°F.

Specials: -50 to 100; 50 to 200; 125 to 225; 175 to 275; 175 to 375; 225 or 425; 275 to 475; 325 to 525°F.

Ambient Temperature Range

-30°F to 130°F.

Linearity

±1°F/100°F.

Hysteresis

Less than 1/4°F.

Time Constant

(To effect 2/3 response to Step ΔT): 50 seconds.

Meter Adjustment

One notch of meter adjustment screw equivalent to 1°F temperature change. CW decreases registration.

Weight Registration

When registration in units of weight (pounds, kilograms, etc.) is required, special meter gearing can be provided so that one revolution of the calibrator output shaft represents a volume equal to a desired quantity of weight. The weight of a certain volume of liquid holds true at only one temperature, however. If the temperature changes, that volume will no longer equal the desired weight, thus, automatic temperature compensation should be used. In general, weight registration error without automatic temperature compensation will equal half the temperature range times the coefficient of expansion of the liquid.

Special meter gearing, dual head gearing, and single head gearing can be provided for certain weight registration requirements. Due to the many variables of meter sizes, weight units, specific gravities, etc., it is advisable to consult the factory regarding particular applications.

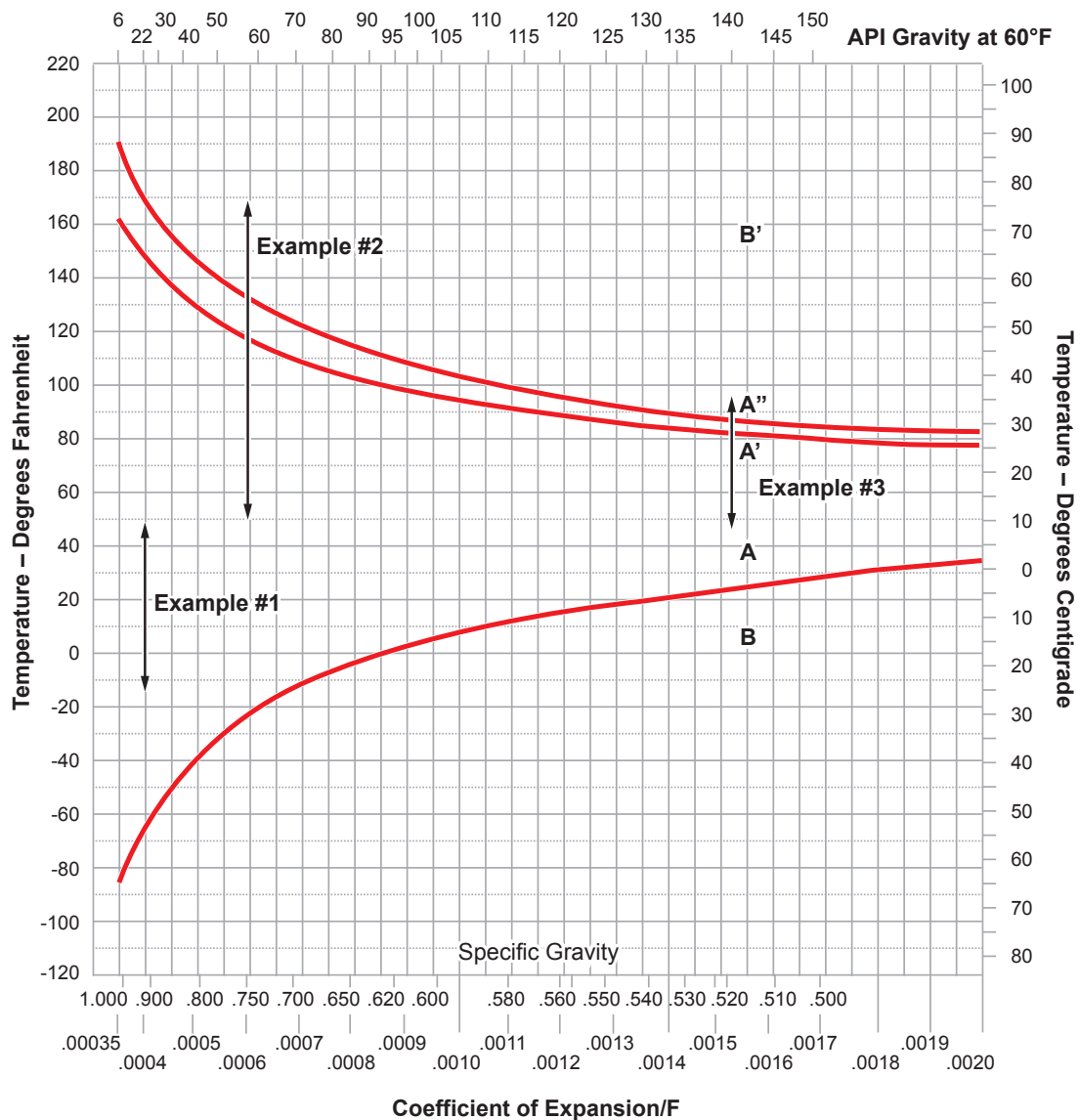

Examples

1.

Product: 22° API.

Temperature Range: -15°F to 50°F.

Special bulb filling only required.

2.

Product: C of E 0.0006.

Temperature Range: 50°F to 170°F.

Special bulb filling and special gearing required.

3.

Product: Specific Gravity 0.520.

Temperature Range: 45°F to 95°F.

Special gearing only required.

Note: This chart is based on correction to base temperatures of 60°F or 15°C. To determine mechanical correction limits for other base temperatures, move the temperature scale so that the desired base temperature coincides with the present 60°F.

Figure 4

Dimensions

Inches (mm)

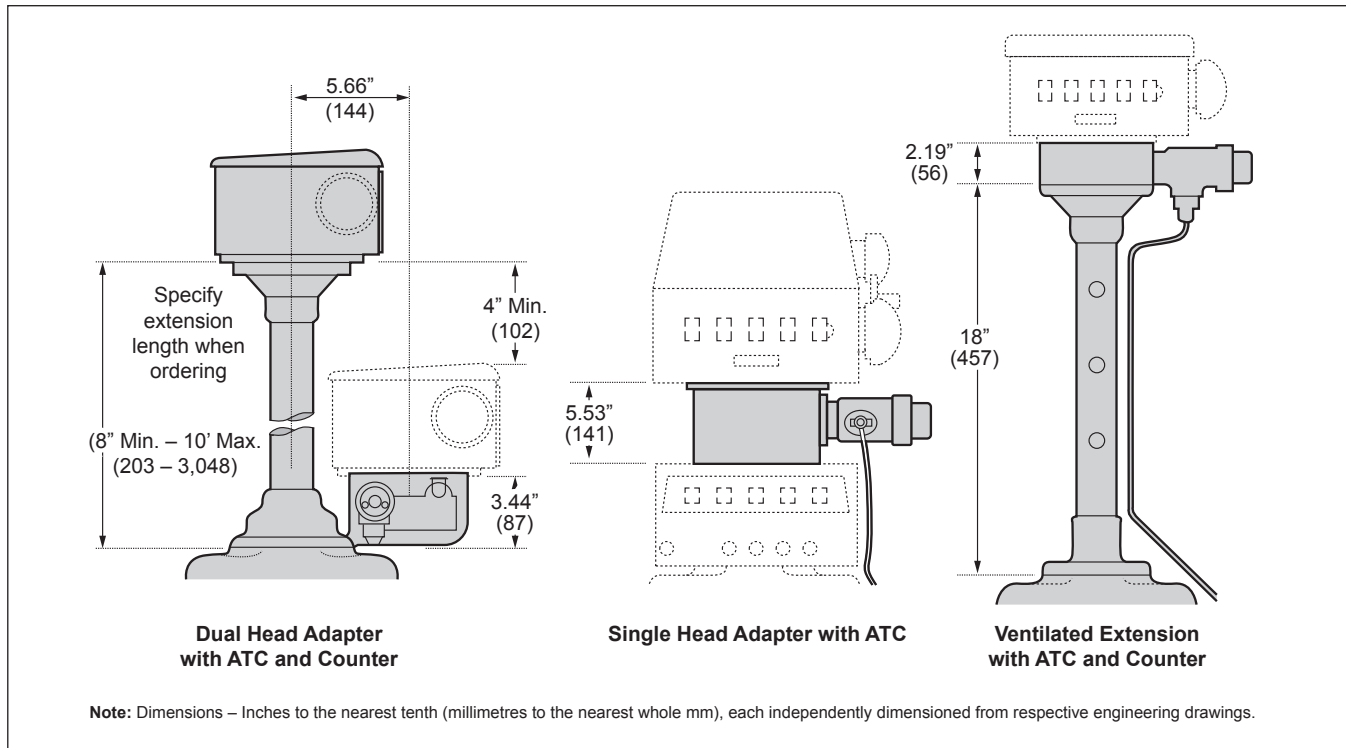

Ordering Information

It is necessary to provide the following information when ordering an ATC.

Temperature	Minimum, maximum, and average
Basis of Correction	API gravity at 60°F, or sp. gr., at 60°F or 15°C. Coefficient of expansion per °F or °C, or sp. gr. at minimum and maximum operating temperatures.
Base Temperature	If other than 60°F or 15°C.
Special Gearing/Special Bulb Filling	Specify if required per Figure 4.

The specifications contained herein are subject to change without notice and any user of said specifications should verify from the manufacturer that the specifications are currently in effect. Otherwise, the manufacturer assumes no responsibility for the use of specifications which may have been changed and are no longer in effect.