

Pipeline Strainers

Bulletin SS03038 Issue/Rev. 0.6 (7/17)

Smith Meter® Strainers

Metering system components require protection against the damage potential of dirt and debris. **Smith Meter® Pipeline Strainers** provide this protection for 4" and larger turbine and positive displacement meter applications.

Standard Features

- 304 stainless steel perforated plate basket
- Blind flange-type cover with lifting lug
- ½" NPT differential pressure taps
- NPT vent and drain taps
- Basket seal
- ASME Section VIII design and fabrication.

Options

- 304 stainless steel basket liners in 10, 20, or 40 mesh.
- Air release kit for static air elimination.
- Basket differential pressure gauge kit with isolation valves to monitor basket cleanliness. Also available with reed switch kit adjustable from 0 – 30 psi (0 – 207 kPa) for remote indication.
- Quick closure style covers.
- NACE compliance. Pressure containing components in compliance with the material requirements of the latest revision of NACE standard MR-01-75 for hydrogen sulfide applications.

Operating Specifications

Maximum Working Pressure

Flange Class	Working Pressure @ 100°F (93.3°C) PSI (kPa)
ANSI B16.5, 150 RF	285 (1,965)
ANSI B16.5, 300 RF	740 (5,102)
ANSI B16.5, 600 RF	1480 (10,204)

¹ Polytetrafluoroethylene (PTFE).



Temperature Range

Elastomer	Range
Non-Asbestos Build flange cover fiber gasket	-20°F to 500°F (-29°C to 260°C)
Optional Cover Seals	C/F
Buna-N (Optional RB air release head)	-20°F to 225°F (-29°C to 107°C)
Viton (Optional RB/UB air release head)	0°F to 400°F (-18°C to 205°C)
PTFE¹ (Optional UB air release head)	-20°F to 450°F (-29°C to 232°C)

Baskets

Perforation/Mesh	Opening Size	Open Area
304 SS perforated plate (standard)	1/8" holes on 3/16" centers	40%
10 mesh liner	0.075"	56%
20 mesh liner	0.034"	46%
40 mesh liner	0.015"	36%

*Open area for liner only, not a combination of liner and perforate plate.

Standard Materials of Construction

Strainer Body/Internals

Housing	Carbon Steel
Flanges	Carbon Steel
Basket	304 Stainless Steel
Optional Mesh Liners	304 Stainless Steel
Cover and Basket Seal	Non-Asbestos Gasket (Blind Flange-Type Cover); Buna-N Quick Closures
Seal	Non-Asbestos Gasket

Optional Air Release Kits

Kit	Pressure Ratings	Seals	Materials
RB-Type	Up to 300 psi (2068 kPa)	Buna-N, Viton	Housing: Carbon Steel; Float: Stainless Steel; Internal Parts: Aluminum, Stainless Steel
UB-Type	Up to 720 psi (4964 kPa)	Viton, PTFE ¹ , Chemraz	Housing: Carbon Steel; Float: Stainless Steel; Internal Parts: Stainless Steel
HP-Type	For 1480 psi (9929 kPa)	Buna-N	Housing: Cast Iron; Float: Stainless Steel; Internal Parts: Stainless Steel

Pressure Drop

Base Model	Flow Units ²	Reference Flow Rate	Pressure Drop at Reference Flow Rate		Base Model	Flow Units ²	Reference Flow Rate	Pressure Drop at Reference Flow Rate	
			psi	Kg/cm ³				psi	Kg/cm ³
03-_-6-B	GPM	500	C/F	C/F	10-_-18-B	GPM	3,290	2.0	0.14
	BPH	720				BPH	4,700		
	m ³ h	115				m ³ h	740		
04-_-10-B	GPM	720	2.5	0.18	10-_-24-B	GPM	11,200	10.0	0.70
	BPH	1,030				BPH	16,000		
	m ³ h	163				m ³ h	2,540		
06-_-12-B	GPM	1,200	2.0	0.14	12-_-18-B	GPM	5,040	3.5	0.25
	BPH	1,714				BPH	7,200		
	m ³ h	273				m ³ h	1,140		
06-_-18-B	GPM	2,800	1.25	0.09	12-_-20-B	GPM	5,040	2.5	0.18
	BPH	4,000				BPH	7,200		
	m ³ h	635				m ³ h	1,140		
08-_-14-B	GPM	1,750	1.5	0.11	12-_-26-B	GPM	15,050	9.0	0.63
	BPH	2,500				BPH	21,500		
	m ³ h	400				m ³ h	3,400		
08-_-20-B	GPM	6,440	8.0	0.56	16-_-24-B	GPM	8,750	3.0	0.21
	BPH	9,200				BPH	12,500		
	m ³ h	1,460				m ³ h	2,000		
10-_-16-B	GPM	2,450	1.5	0.11	16-_-36-B	GPM	23,450	9.3	0.65
	BPH	3,500				BPH	33,500		
	m ³ h	550				m ³ h	5,325		

1 Polytetrafluoroethylene (PTFE).

2 Metric Units are nominal and may not convert precisely.

3 Estimated Pressure Drop based upon 0.8 s.g., 2.0 cP liquid, clean perforated plate basket with 1/8" holes on 3/16" centers. For pressure drop with liners, multiply by the following factors: 10 mesh: x 1.25; 20 mesh: x 1.30; 40 mesh: x 1.35.

Modeling*

Example: **10 - 1 - 18 - B - 8 - PP - N - PL - T - 0**

Flange Size

04 - 4" **10** - 10"

06 - 6" **12** - 12"

08 - 8" **16** - 16"

ANSI Flange Class/Max. Working Pressure @ 100° F (38° C)

1 - Class 150 RF / 285 psi

3 - Class 300 RF / 740 psi

6 - Class 600 RF / 1480 psi

Body Diameter (Inches)

Closure Style

B - Blind flange
(standard - all ratings)

S - Swing bolt
(optional for 150# only)

D - Davit
(optional for 300# / 600# only)

Design

8 - ASME Sect VIII

Special Features

0 - None

D - Dye penetrant

M - Mag particle

N - NACE

S - Special

X - 100% X-ray

Differential Pressure Gauge/Switch

T - None - pressure taps only (standard)

G - Differential pressure gauge

S - Differential pressure gauge and switch kit

Vent / Air Release

PL - Plugged NPT vent port (standard)

R1 - RB Head w/ Buna-N, 300 psig

R2 - RB Head w/ Viton, 300 psig

U1 - UB Head w/ Viton, 720 psig

U2 - UB Head w/ PTFE¹, 720 psig

U3 - UB Head w/ Viton, 300 psig

U4 - UB Head w/ Chemraz, 300 psig

HP - High pressure type w/ Buna-N, 1480 psig w.p.

Cover Seals

N - Non-asbestos fiber gasket (standard with blind flange and davit closures)

B - Buna-N (swing bolt-style closures)

S - Special

Basket

PP - 304 SS perforated plate - no liner (standard)

10 - Basket + 10 mesh 304 SS permanent liner

20 - Basket + 20 mesh 304 SS permanent liner

40 - Basket + 40 mesh 304 SS permanent liner

SP - Special

* Standard design includes carbon steel body, blind flange-type cover with lifting lug and non-asbestos fiber gasket, 304 SS perforated plate basket, NPT differential pressure, vent and drain taps, fabrication in accordance with ASME B31.3

¹ Polytetrafluoroethylene (PTFE).

Dimensions and Weights

Inches
(mm)

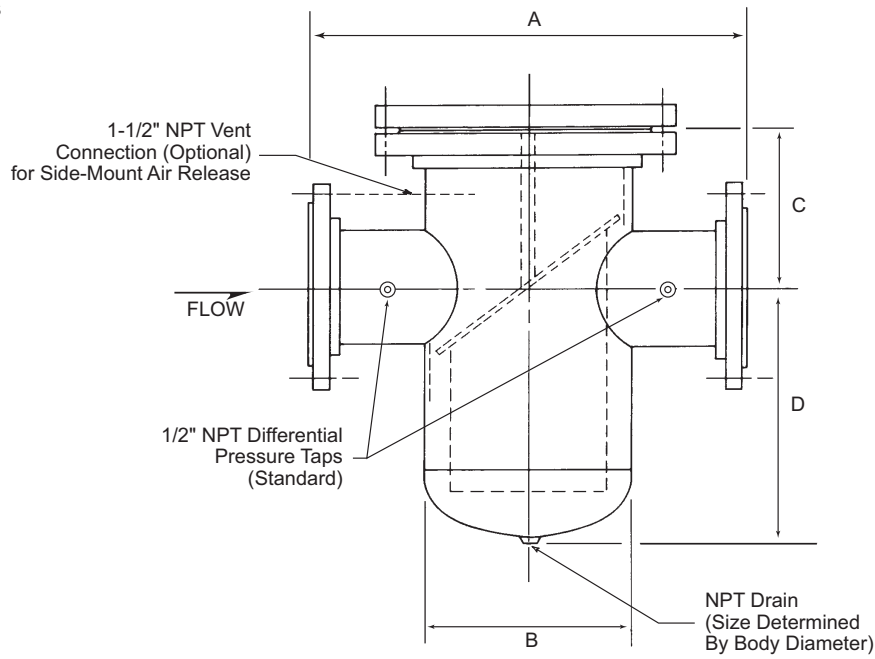

Note: Dimensions are for reference only. Actual certified dimensions available after order placement and pending acceptance of approval drawings.

ANSI Flange Class										NPT Drain Size Inches (mm)
Base Model	A			B	C *†	D †	Estimated Net Weight Lbs. (kg)			
	150	300	600	150/300/600			150	300	600	150/300/600
03-_-6-B	13.5 (343)	20.9 (531)	23 (584)	6 (152)	7.5 (190)	11.6 (295)	130 (59)	190 (86)	300 (136)	.75 (19)
04-_-10-B	18 (457)	20 (508)	23 (584)	10 (254)	11 (279)	16 (406)	315 (143)	500 (227)	750 (340)	1.25 (32)
06-_-12-B	25 (635)	25 (635)	30 (762)	12 (305)	11 (279)	21 (533)	420 (190)	675 (306)	1,000 (453)	1.5 (38)
06-_-18-B	46 (1,168)	46 (1,168)	50 (1,270)	18 (457)	15 (381)	23 (584)	790 (358)	1,225 (556)	2,150 (975)	1.5 (38)
08-_-14-B	28 (711)	28 (711)	34.5 (876)	14 (356)	13 (330)	21 (533)	590 (268)	850 (385)	1,400 (635)	1.5 (38)
08-_-20-B	48 (1,219)	48 (1,219)	52 (1,321)	20 (508)	16 (406)	33 (838)	700 (317)	1,600 (726)	2,800 (1,270)	2 (51)
10-_-16-B	32 (813)	34 (864)	36 (914)	16 (406)	16 (406)	25 (635)	725 (329)	1,100 (499)	1,900 (862)	1.5 (38)
10-_-18-B	36 (914)	36 (914)	42 (1,067)	18 (457)	16 (406)	30 (772)	870 (395)	1,350 (612)	2,350 (1,066)	1.5 (38)
10-_-24-B	57 (1,448)	57 (1,448)	62 (1,575)	24 (610)	18 (457)	30 (772)	1,200 (544)	2,475 (1,123)	4,100 (1,860)	1.5 (38)
12-_-18-B	36 (914)	36 (914)	42 (1,067)	18 (457)	16 (406)	27 (686)	950 (431)	1,525 (692)	2,500 (1,134)	1.5 (38)
12-_-20-B	48 (1,219)	48 (1,219)	54 (1,372)	20 (508)	16 (406)	33 (838)	1,120 (508)	1,950 (884)	3,100 (1,406)	1.5 (38)
12-_-26-B	57 (1,448)	57 (1,448)	62 (1,575)	26 (660)	20 (508)	33 (838)	1,600 (725)	2,850 (1,293)	4,100 (1,860)	1.5 (38)
16-_-24-B	44 (1,118)	44 (1,118)	62 (1,575)	24 (610)	21 (533)	35 (889)	1,600 (725)	2,950 (1,338)	5,000 (2,268)	2 (51)
16-_-36-B	68 (1,727)	68 (1,727)	62 (1,575)	36 (914)	24 (610)	46 (1,168)	2,285 (1,037)	C/F	C/F	2 (51)

Note: Dimensions – Inches to the nearest tenth (millimetres to the nearest whole mm), each independently dimensioned from respective engineering drawings.

* Not applicable to Class 600 lb.

† Approximate dimensions.

Editorial change made June 2020 – Option moved to Feature.

The specifications contained herein are subject to change without notice and any user of said specifications should verify from the manufacturer that the specifications are currently in effect. Otherwise, the manufacturer assumes no responsibility for the use of specifications which may have been changed and are no longer in effect.