

Smith Meter® AccuLoad® III-Split Architecture

Bulletin SS06039 Issue/Rev. 0.6 (2/19)

Electronic Preset Delivery System

The Smith Meter® AccuLoad® III Split Architecture System is a multiple arm, multiple meter control and measurement system used to control a lane of loading arms. The system is designed to mount in either a Division 2 approved area or a General Purpose area. Up to 18 loading arms and 24 meters can be controlled and monitored by the system, which includes the Man Machine Interface (MMI) and the Flow Control Module (FCM). The MMI provides the display and keypad for the system, while the FCM houses the control and I/O for the loading arms. These loading arms can be controlled either as blended or straight product arms. The system has the flexibility of handling multiple blending applications, straight ratio blending, side stream blending, and up to six-product sequential blending on the same loading lane. Using a single MMI, up to six arms can be loaded simultaneously. Using two MMIs, up to twelve arms can be loaded simultaneously. The AccuLoad III has flash memory allowing for easy firmware upgrades and large storage capability.

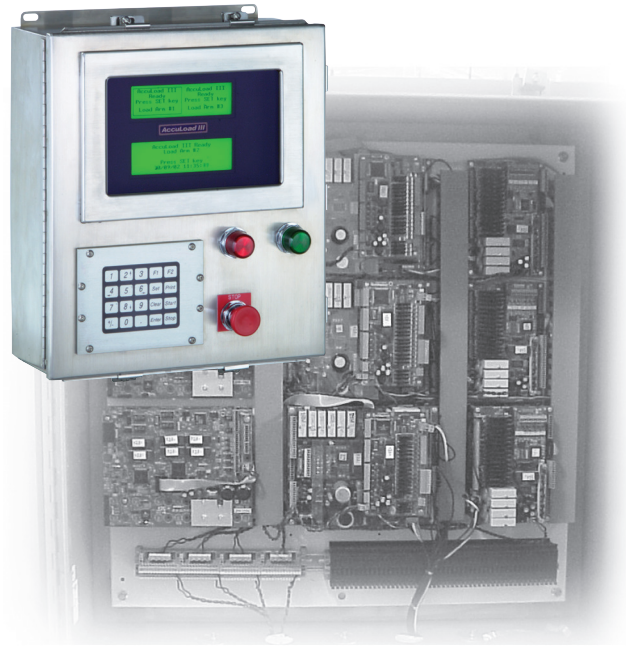

Features

- Up to 24 single or dual pulse product meter inputs
- Up to 56 additive meter inputs with local I/O
- Up to 96 additive meter inputs with remote I/O
- Up to 18-arm operation
- Each arm programmable for straight product, sequential blending, ratio blending, or side stream blending
- Up to 50 recipes per board set
- Up to four board sets per system
- User-configurable inputs and outputs
- Block valve control and feedback (sequential blending)
- Additive control (metered, pulse out or communications)
- Four communication ports plus Ethernet port
- Meter factor calculation
- Programmable language/messages
- Turbine meter diagnostics
- Boolean/Algebraic processing
- Event logging/Audit trail
- Stand-alone operation
- Configurable load ticket/BOL emulation printing
- Continuous monitoring of critical functions
- Two-way data communications; built-in communication analyzer
- Automatic temperature and pressure compensation and density correction
- API tables from LPG to crude oil
- Optional Proximity Card Reader
- Integral Driver Database
- GPA Tables TP-15 and TP-16
- Five levels of security
- Automatic flow control with recovery
- Programmable valve control
- Dual MMI for Swing Arm Operations
- Stainless steel enclosures on MMI and FCM
- Transaction Data Archive (optional) also known as ComFlash Mass Storage Expansion Board
- Flash based memory
- Ethernet connectivity features (see page 4)
- Card Reader Interface
- Smith Meter®/Sening® Blue Tooth Connectivity

Applications

The AccuLoad III Split Architecture System provides a unique solution for controlling the batch loading of products through multiple load arms. An entire lane of up to 18 loading arms and 24 meters can be controlled with one system. (A maximum of six arms can be operated simultaneously, or a maximum of twelve arms when using two MMIs.) The system is ideal for truck, barge, or rail car loading at loading racks, bulk plants, shipping docks, processing installations, and tank farms where straight products, as well as blended products, must be accurately loaded.

Standard Features

The following descriptions of straight product, sequentially-blended product, ratio-blended product, and side stream blended product loading are written as if all loading arms are programmed for that type of loading. In reality, all the following combinations of loading arm configurations are available in the AccuLoad III Split Architecture System.

Straight Product

The AccuLoad III-Split Architecture System is designed to handle up to 18 arms of straight products. Six products can be loaded simultaneously with a single MMI, and twelve products with dual MMIs.

Sequential Blending

The AccuLoad III-Split Architecture System is designed to sequentially control the loading of up to six petroleum or chemical products through each of up to 18 loading arms. Six of the loading arms can be loaded simultaneously with a single MMI, and twelve with dual MMIs.

Ratio Blending

The AccuLoad III-Split Architecture System is designed to control the blending of up to six petroleum products through a single loading arm. All products flow through a metering system, are co-mingled downstream of the metering system, and flow through a single loading arm into a transport or into storage. Since each of the loading arms are programmable, the unit could be programmed for four load arms to be programmed as six-product blenders or 12 load arms programmed to be two-product blenders.

Side Stream Blending

The AccuLoad III-Split Architecture System is designed to control the blending of a minor product and a major product. The minor product is metered and controlled by a valve and the main product is free flowing. A second meter and control valve is located down stream of the blending point and measures/controls the flow of the blended product.

Hybrid Blending

The AccuLoad III supports hybrid blending which is defined as a combination of sequential blending and ratio blending. A typical hybrid blending arm configuration may be three sequential products and one or two ratio products. The sequential products flow one at a time and in most cases one of the ratio products would flow simultaneously with each of the sequential products. The ratio product(s) can be plumbed either upstream or down stream of the sequential product meter. On a hybrid arm there must be at least one sequential product configured.

Wild Stream Blending

The AccuLoad also supports Wild Stream Blending, which allows for continuous (no preset entered) ratio blending of products. One of the products can be uncontrolled (wild stream). This option is also available with the hybrid arm configuration. Wild Stream Blending supports "on the fly" blend percent changes and also for changing meters to accommodate varying flow rates.

Temperature Compensation

The temperature compensation option provides the customer with the capability of compensating for the variance in temperature from a reference temperature. This option is used with an RTD input or a temperature transducer and, excluding the accuracy of the fluid temperature measurement, will exactly match the proper volume correction factor of ASTM-D-1250-04 and API MPMS CH 11.1 - 2004 over the fluid temperature range of -40°F to 572°F (-40°C to 300°C). The following API tables can be programmed in the AccuLoad III: 5A, 5B, 5D, 6, 6A, 6B, 6C, 6D, 23, 23A, 23B, 23D, 23E, 24, 24A, 24B, 24D, 24E, 53, 53A, 53B, 53D, 54, 54A, 54B, 54C, 54D, 59A, 59B, 59D, 60A, 60B, 60D, BR1A, BR1P, and BR2P.

Pressure Compensation

The pressure compensation option provides the customer with the capability of compensating the volume of product delivered at varying pressures per API Tables 11.2.1 and 11.2.2, using a 4-20 mA pressure transducer input per preset position. This option also contains real-time control functions for maintaining system pressures at the meter to a minimally-acceptable, user-definable level (pressure transducer not included). This option is particularly useful for light products, such as LPG, where the compressibility factor varies a great deal with different pressures.

Density Correction

The density correction option provides the customer with the capability of correcting the volume of product delivered at varying densities. This can be either a frequency input or a 4-20 mA input.

Metered Injectors, Piston Injectors and Smart Additives

The AccuLoad III has been designed to provide maximum flexibility when it comes to additive control. The unit is capable of handling metered injectors, piston injectors and smart additives simultaneously.

The AccuLoad is capable of controlling four additive injector metered systems per board set. **(See Hardware Options for additional injector systems.)** The AccuLoad controls the additive solenoids to precisely inject the additive into the main product. It monitors the pulses of the additive meter and controls the amount of the additive, based on the incoming pulses from the additive meter and the main product meter.

Additive monitoring and smart additives provide the capability for the AccuLoad to monitor the feedback from the piston injectors of the additive products. The AccuLoad monitors the injector feedback switches for a change of state and counts the errors and alarms if no change is detected within the cycle or a period of time, depending on how the unit is programmed. The AccuLoad will totalize the additive volume based on confirmation signals and a programmable volume per cycle. The totalized volume will print on the emulated load ticket printed on the shared printer output.

For Smart additives, the firmware has also been designed with a Master/Slave type of communications, with the AccuLoad being the master and the Additive Injector System being the slave. The AccuLoad constantly interrogates the Additive Injector System for a change in status. The AccuLoad can be operated with communications control over the Smart Additive Injector System or with communication/pulse control. When the AccuLoad has communication control over the Additive System, it will constantly monitor the Additive System for its status, poll the additive totals, and signal the system when to inject the additive – all through the communications line.

The AccuLoad communications package has also been designed with a pass-through communications mode. In this mode of operation the supervisory computer can talk to the Additive Injector System through the communication lines that have been run to the AccuLoad and from the AccuLoad to the Additive Injector System(s).

Dual Pulse Security

This option provides continuous monitoring, error indication alarm, and correction of the pulse transmission for each preset position per API Petroleum Measurement Standard, Chapter 5.5, Level A, and Institute of Petroleum Standard, IP 252/76, Part XIII, Section 1, Level A (PPS High-Security Pulse Transmitter is not included). The PPS High-Security Transmitter provides four signals: "A," "A inverted," "B," and "B inverted." The "A" and "B" signals are 90 electrical degrees out-of-phase and used for dual-pulse security. The "A" and "A inverted," and "B" and "B inverted" signals are 180 electrical degrees out-of-phase and are used for transmitter

power sensing. If power sensing is not required, only "A" and "B" are used for dual-pulse security.

When using dual pulse transmitters and if using the maximum on each set of hardware, all metered injectors would have to be set up using the optional AICB board.

Automated Proving Mode

The AccuLoad III firmware provides an automated proving mode of operation. When the automated proving mode is activated the AccuLoad will calculate the meter factor for a proving run based on information that is obtained during the prove. The operator can select the flow rate and meter factor that is being proved through the keypad of the AccuLoad. After the prove is complete the operator enters the prover volume and prover temperature and the AccuLoad will calculate the new meter factor and the operator has the choice of downloading it to the program or to ignore it. The AccuLoad also has the capability of providing an average meter factor over a maximum of ten proves. This feature allows the operator to prove the meter on all four products, and four meter factors and associated flow rates for each product without having to enter the program mode for each product and meter factor.

Boolean and Algebraic Processing

The AccuLoad III provides the customer the flexibility to set-up inputs and outputs for tasks that are not standard in the unit. Through Boolean processing, relays can be turned on and off through equations and events set up by the customer. For example, a relay is required to close at the first trip point of the load. This can be set up using Boolean processing and does not require special software from Smith Meter.

Algebraic processing is also an area that the customer can use to do simple mathematical calculations that are not in the unit. These calculations can then be used on the configurable reports for the current batch being run by the unit.

Hardware Options

Flow Control Module

AccuLoad Interface Control Board

The AccuLoad Interface Control Board provides additional flexibility to the AccuLoad's standard features. The optional AICB Board provides either ten additional metered additive injector systems or twenty additional programmable outputs per board set. With the optional AICB Board, the AccuLoad III with firmware has the capability of handling up to fourteen metered injectors, fourteen meter inputs, fourteen solenoid valve outputs, and fourteen additive pump outputs. A second AICB board per board set can be added in a remote housing to provide the capability of each board set to handle up to twenty-four additive injector systems (meters, additive pumps, and solenoid valves) or an additional forty programmable AC outputs. The optional AICB Board(s) are designed

to either be mounted in the AccuLoad III housing or in a stand-alone enclosure. One of the four communication ports is required to communicate with the AICB Board.

ComFlash Mass Storage Expansion Board

This optional hardware module provides additional non-volatile memory to store transaction data. The module comes with a 512 M SD card that has the capacity of storing thousands of additional transactions. The module is only available on COM 4 and uses RS232 communications. The A3X also provides alarms for the expansion board to ensure proper operation. The Smith Meter Proximity Card Reader can also operate on COM 4 in conjunction with the ComFlash board.

Man Machine Interface (MMI)

The Division 2-approved Man Machine Interface (MMI) may be ordered with optional green and red indicator lights, and/or a "stop" button. These are user-wired devices. The indicator lights can be used in place of the indicator lights on the overflow/ground system. The MMI can also be ordered with a proximity card reader. (Refer to Specification Sheet SS06044 for card reader details.)

Fuse Holders

Up to 50 fuse holders can be mounted in the Division 2 enclosure. These fuse holders can be used as additional protection for wiring to valve solenoids, etc. If required for the General Purpose, rack-mountable units, the fuse holders would be mounted in the customer's rack on a DIN rail.

ETHERNET CONNECTIVITY FEATURES

- ARP/RARP and DHCP support
- PING echo diagnostics
- SLIP
- FTP file transfer
- Smith Meter protocol and Modbus protocol support over TCP/IP
- Limited HTTP server functionality
- Dynamic name server lookups (DNS client)
- Simple Mail Transport Protocol (SMTP)
- Post Office Protocol V3 (POP3)
- A collection of HTML and XML pages and CGI scripts
- Web server – command line argument passing
- Support for network printers (LPR client)
- The addition of a Remote Display/TCP daemon to the AccuLoad III
- Compliance with TCP/IP standards

Specifications (AccuLoad III)

Accuracy

Calculated Accuracy: The gross at standard temperature to gross volume ratio, excluding the accuracy of fluid tempera-

ture measurement, will exactly match the proper volume correction factor of ASTM-D-1250-04 over the fluid temperature range of -40°F to 572°F (-40°C to 300°C).

Temperature Measurement Accuracy: Fluid temperature is measured to within $\pm 0.72^\circ\text{F}$ ($\pm 0.4^\circ\text{C}$) over the fluid temperature range of -148°F to 572°F (-100°C to 300°C). Fluid temperature is measured to within $\pm 0.45^\circ\text{F}$ ($\pm 0.25^\circ\text{C}$) over the fluid temperature range of 32°F to 572°F (0°C to 300°C).

Stability: 0.1°F (0.06°C)/year.

Flow Totalizing: Within one pulse of input frequency.

Electrical Inputs (Per Board Set)

AC Instrument Power:

Universal input 100 to 240 Vac, 58W maximum, 48 to 63 Hz. The AC circuitry is fuse-protected.

Surge Current: 28A maximum for less than 0.1 seconds.

Power Interruption Tolerance: Interruption of power greater than .05 seconds (typical) will cause an orderly shut-down of the AccuLoad and the control valve will be immediately signaled to close.

Note: A constant voltage transformer (CVT) is recommended if the available AC power is suspected not to comply with these specifications.

Pulse Input:

Type: High-speed, edge-triggered, optically isolated pulse transmitter input. The input pulse must rise above V (high min.) for a period of time and then fall below V (low) to be recognized as a pulse by AccuLoad III.

V (High): 5 Vdc minimum to 28 Vdc maximum.

V (Low): 1 Vdc maximum.

Input Impedance: 1.8 K Ω .

Pulse Resolution: 1 pulse/unit minimum, 9,999 pulses/unit maximum.

Frequency Range: 0 to 10.0 kHz.

Response: Within one pulse to a step change in flowrate.

Mode: Single, dual, dual with power sensing, density.

Duty Cycle: 35/65 to 65/35 (on/off).

Temperature Probe:

Type: four-wire, 100 Ω Platinum Resistance Temperature Detector (PRTD).

Temperature Coefficient: @ 32°F: 0.00214 $\Omega/\Omega/^\circ\text{F}$ (0.00385 $\Omega/\Omega/^\circ\text{C}$).

Temperature Range: -148°F to 572°F (-100°C to 300°C).

Offset: Temperature probe offset is program-adjustable through the AccuLoad keypad in ± 0.1 degree increments in the unit of temperature measurement used.

Self-calibrating: Lead length compensation that requires no resistance balancing of leads.

Analog (4-20 mA):

Type: Two-wire, 4-20 mA current loop receiver, isolated from ground, programmable as to function.

Span Adjustment: Program-adjustable through the AccuLoad keypad or communication in tenths of the unit used.

Input Burden: 50 Ω .

Accuracy: $\pm 0.025\%$ of range.

Resolution: One part in 65,536.

Voltage Drop: 2 Volts maximum.

Sampling Rate: One sample/300 mSec minimum.

Analog (1-5 Vdc):

Type: Two-wire, 1-5 Vdc voltage loop receiver, isolated from ground, programmable as to function.

Span Adjustment: Program-adjustable through the AccuLoad keypad or communications in tenths of the unit used.

Input Burden: 1 m Ω .

Accuracy: $\pm 0.025\%$ of range.

Resolution: One part in 65,536.

Sampling Rate: One sample/300 mSec minimum.

AC Inputs:

Type: Optically-isolated, solid-state voltage sensor.

Input Voltage Range: 90 to 280 Vac.

Pickup Voltage: 90 Vac minimum.

Drop-out Voltage: 30 Vac maximum.

Current at Maximum Voltage: 20 mA maximum.

Input Resistance: 44,000 Ω typical.

DC Inputs:

Type: Optically-isolated solid state voltage sensors.

Input Voltage Range: 5 to 28 Vdc.

Pickup Voltage: 5 Vdc minimum.

Drop-out Voltage: Less than 1 volt.

Current at Maximum Voltage: 20 mA maximum.

Input Level Duration: 120 mSec minimum.

Keypad:

Type: Metal encapsulated, one-piece, sealed, no moving parts, piezoelectric design. Protected against the environment.

Display:

The Graphics Display is a 240 by 64 pixel graphic Liquid Crystal Display (LCD) module with LED backlighting.

Electrical Outputs (Per Board Set)**DC Power:**

24 Vdc $\pm 10\%$, 1 A maximum, short circuit protected.

AC Outputs:

Type: Optically-isolated, AC, solid-state relays. User-programmable as to function.

Load Voltage Range: 90 to 280 Vac (rms), 48 to 63 Hz.

Steady-State Load Current Range: 0.05A (rms) minimum to 1.0A (rms) maximum into an inductive load.

Leakage Current at Maximum Voltage Rating: 5.2 mA (rms) maximum @ 240 Vac.

On-State Voltage Drop: 2 Vac at maximum load.

Frequency Range: 0-1 Hz.

DC Outputs:

Type: Optically-isolated solid state output. User-programmable as to function.

Polarity: Programmable (normally open or normally closed).*

Switch Blocking Voltage: 30 Vdc maximum.

Load Current: 150 mA maximum with 0.6 volt drop.

Frequency Range: 0-1 Hz.

Note: *Power-down normally open.

Analog (4-20 mA):

Type: Two-wire, 4-20 mA current loop transmitter, isolated from ground, programmable as to function.

Span Adjustment: Program adjustable through the AccuLoad keypad or through communications.

Accuracy: $\pm 0.025\%$ of range.

Resolution: One part in 65,536.

Voltage Burden: 4 volts maximum.

Analog (1-5 Vdc):

Type: Two-wire, 1-5 Vdc voltage loop transmitter, isolated from ground, programmable as to function.

Span Adjustment: Program adjustable through the AccuLoad keypad or through communications.

Accuracy: $\pm 0.025\%$ of range.

Resolution: One part in 65,536.

Pulse Output 1 & 2:

Type: Optically-isolated solid state output. Pulser output units are program-selectable through the AccuLoad keypad or communications.

Polarity: Programmable (normally open or normally closed).

Switch Blocking Voltage (Switch Off): 30 Vdc maximum.

Load Current (Switch On): 10 mA with 0.6 volts drop.

Frequency Range: 0 to 3000 Hz.

Duty Cycle: 50/50 (on/off).

Pulse Output 3, 4 & 5:

Type: Solid state relay digital output switch

Load Current: 110mA max.

Frequency Range: 0-125Hz

Duty Cycle: 50/50 (on/off)

Programmable maximum frequency output. All intended pulses will be eventually transmitted, the total period may increase to ensure all pulses are output.

Note: When used, these outputs use the DC output points on the KDC (DC output 1-3 respectively and also the 3 digital inputs 1-3 respectively).

Environment

Ambient Operating Temperature:

-40°F to 140°F (-40°C to 60°C).

Humidity:

5 to 95% with condensation.

Enclosure:

Industrial type 4X, stainless steel.

Electrical Safety Approvals

UL/CUL

Class I, Division 2, Groups C & D; UNL-UL Enclosure 4X, CNL-CSA Enclosure 4.

Class I, Zone 2, Group IIB.

UL/CUL File E23545.

Notes: The Standard AccuLoad III does not contain intrinsically-safe circuitry; therefore, all peripheral equipment must be suitable for the area in which it is installed.

Weights & Measures Certifications

United States NTEP Certificate of Conformance issued by the National Conference on Weights and Measures CC 99-141

Canadian Notice of Approval, issued by Measurement Canada AV-2361

For other please consult factory.

AccuLoad III-MMI Weight: Approximately 35 lb (15.90 kg).

AccuLoad III-FCM Weight: Approximately 120 lb (54.54 kg).

Communications (Per Board Set)

General

Number of Ports: Four, plus Ethernet port.

Configuration: Multi-drop network. Standard IT practices should be followed when connecting multiple AccuLoad IIIs via an Ethernet hub, router, or switch.

Data Rate: Keypad-selectable to asynchronous data rates of 1200, 2400, 3600, 4800, 7200, 9600, 19,200, or 38,400 bps (serial comm).

Data Format: Programmable one start bit, programmable seven or eight data bits – even, odd, or no parity, one stop bit.

Line Protocol: Half-duplex, full-duplex, no character echo.

Data Structure: ASCII character-oriented, modeled after ISO Standard 1155.

Protocol: Smith ASCII LRC, Smith ASCII CR, Smith ASCII binary, Modicon Modbus (PI-MBUS-300 Rev. D).

AccuLoad II Style: Terminal Mode, Minicomputer Mode.

Ethernet: 10/100 Base TRJ-45 8-10 pin UTP (unshielded twisted pair) connector.

EIA-232 (1 dedicated, 2 selectable)

Type: Interfaceable with EIA-232 data communication standards. Data transmitters are tri-state design.

Typical Applications: Product receipt ticket printing (used with a stand-alone ASCII printer or as a backup in the standby mode with automation for BOL emulation) or communications with Product Management Automation Systems. Up to 16 AccuLoads can be connected onto the same transmit and receive data lines.

EIA-485 (1 dedicated, 2 selectable)

Type: Interfaceable with EIA-485 data communication standards.

Typical Application: Communications with Product Management Automation Systems.

Number of Units per Communication Line: Up to 32 AccuLoads can be connected onto the same transmit and receive data lines.

Specifications (AICB Board – Optional)

Electrical Inputs

DC Instrument Power:

24 Vdc \pm 10%, 1 watt maximum

Pulse Input:

Type: High-speed, edge-triggered, optically isolated, compatible with contact closure, open collector or voltage sink/source pulse transmitter input. The input pulse must rise above V (high min.) for a period of time and then fall below V (low) to be recognized as a pulse.

V (High): 10 Vdc minimum to 24 Vdc maximum.

V (Low): 8 Vdc maximum.

Pulse Resolution: 1 pulse/unit minimum, 9,999 pulses/unit maximum.

Frequency Range: 0 to 5 kHz.

Response: Within one pulse to a step change in flow rate.

Minimum Pulse Width: 50 μ S.

Electrical Outputs

AC Outputs:

Type: Optically-isolated, AC, solid-state relays.
User-programmable by the host as to function.

Load Voltage Range: 90 to 275 Vac (rms), 48 to 63 Hz.

Steady-State Load Current Range: 0.05A (rms) minimum to 0.5A (rms) maximum into an inductive load.

Leakage Current at Maximum Voltage Rating: 0.1mA (rms) maximum at 240 Vac.

On-State Voltage Drop: 1.5 Vac at maximum load.

Environment

Ambient Operating Temperature:

-40°F to 140°F (-40°C to 60°C).

Humidity:

5 to 95% with condensation.

Remote Enclosure:

Explosion-proof (NEMA 7, Class I, Groups C and D) and watertight (NEMA 4X), IP65

Electrical Safety Approvals (Remote Enclosure)

UL/CUL:

Class I, Division 1, Groups C and D; Class II, Groups E,

F and G, UNL-UL Enclosure 4X, CNL-CSA Enclosure 4

Class I, Zone 1, AEx d IIB T6, IP65

UL File E23545

ATEX / IEC Ex:

DEMKO 11 ATEX 1103869X IEC Ex UL 11.0029X

Ex d IIB T6 IP65 Tamb = -40°C to +60°C

Specifications (Red and Green Indicating Light Units – Optional)

Electrical Ratings

Bulbs:

LED Lamp, 120V AC in Red or Green

Terminals

Saddle clamp type for 1 x 22 AWG

Specifications (Stop Button – Optional)

Electrical Ratings

Contact Block:

A600 (AC): 120V maximum

Make and Emergency Interrupting Capacity (Amps):
60 (120V); 30 (240V)

Normal Load Break (Amps): 6 (120V); 3 (240V)

Thermal Current (Amp): 10

Voltamperes: Maximum Make 7200; Maximum Break
720

Contact Type: 1N0-1NC (Momentary)

Color: Black

Terminals

Stainless steel saddle clamp type for 1 x 18 - 14 AWG
(0.75 - 2.5 sq. mm) solid or stranded copper conductor

Modeling¹

Man Machine Interface – Division 2 Approved

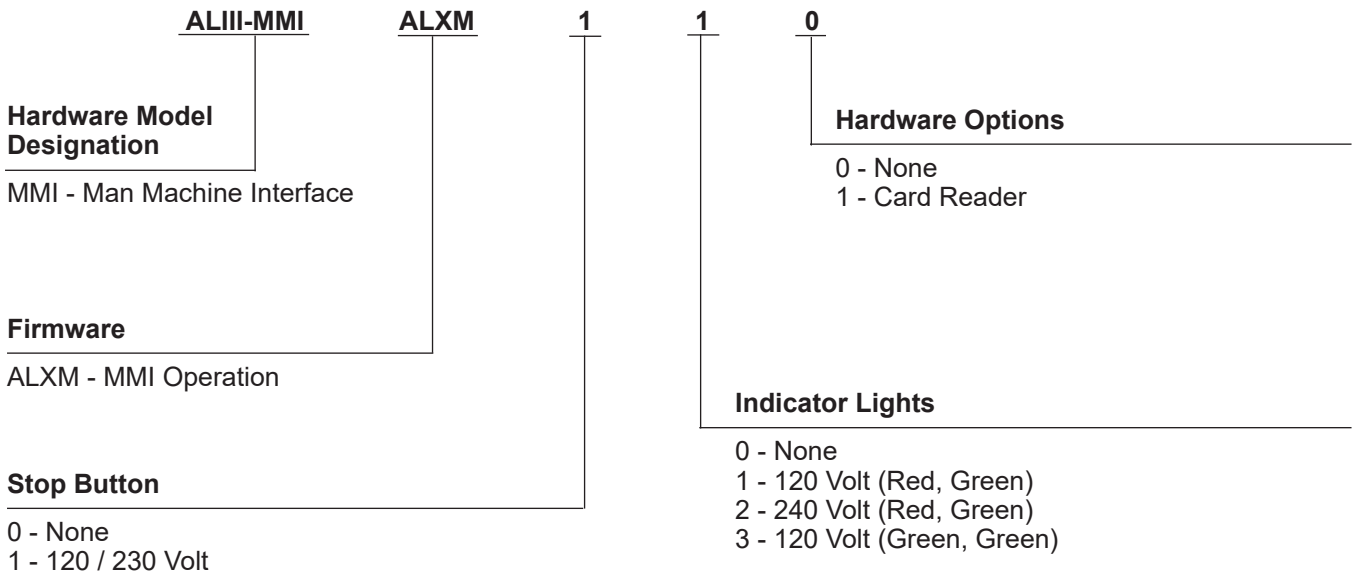

Flow Control Module - Division 2 Approved

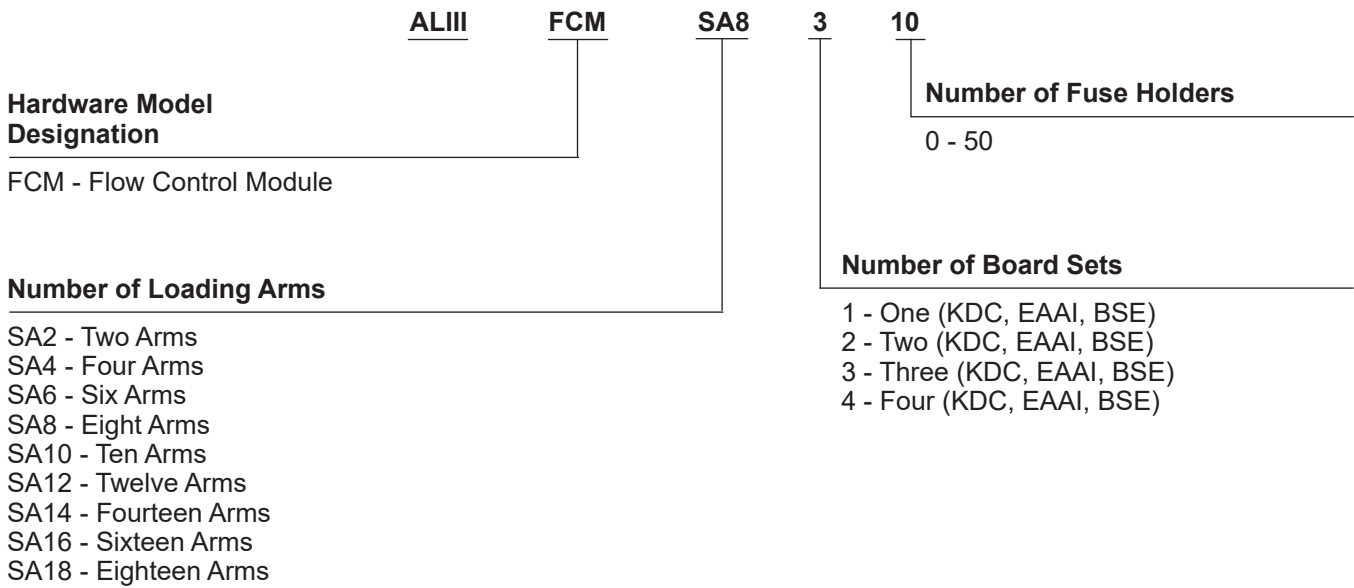

¹ A complete model number is required when ordering the AccuLoad III.

**Board Set Modeling – Flow Control Module – Division 2 Approved (Continued)
(One Required for Each Set of Boards Installed, KDC, EAAI, and BSE)**

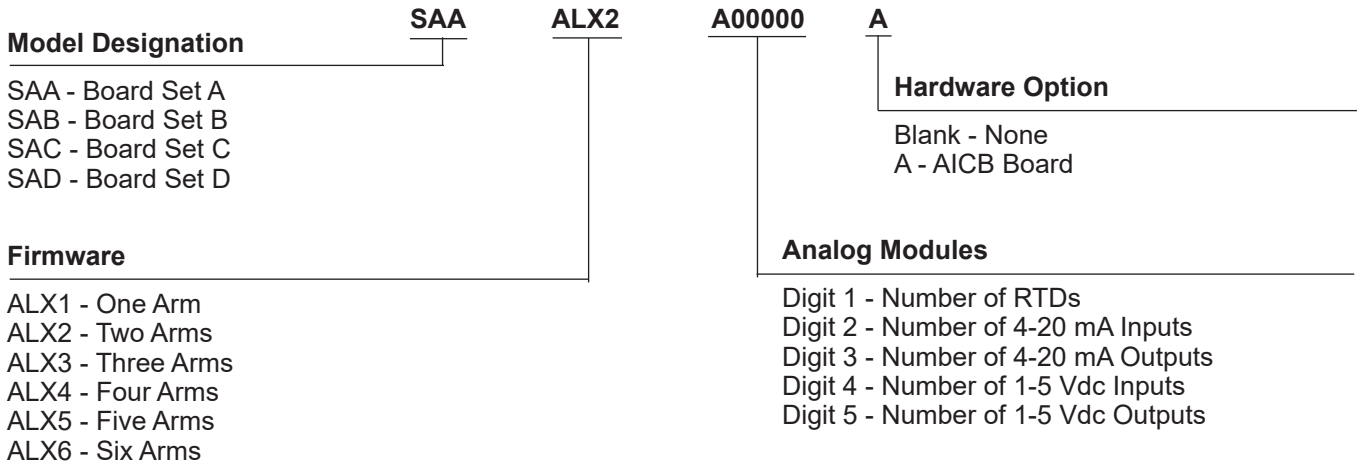

Modeling (AICB Board Remote Mount)

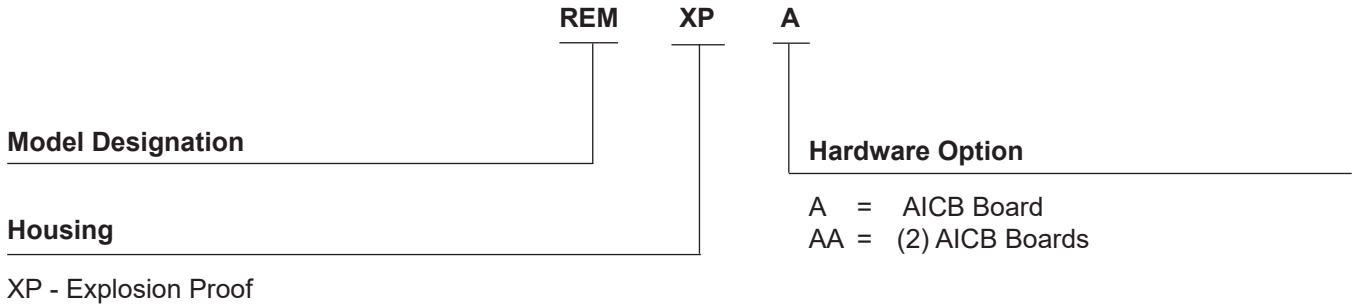

Programmable Inputs/Outputs²

Per Board Set

Digital Inputs	AC	DC	Total
Standard	9	14 ²	23
Optional (One AICB)	9	24	33
Digital Outputs			
	AC	DC	Total
Standard	27	11 ²	38
Optional (One AICB)	47	11	58
Analog Inputs/Outputs – Up to 6			

The AccuLoad III Split Architecture System is flexible in that the TechnipFMC module can be supplied with one to four board sets

Digital Inputs Per Board Set			Total			
Description	AC	DC	1 Board Set	2 Board Sets	3 Board Sets	4 Board Sets
Standard	9	14 ²	23	46	69	92
Optional AICB	9	24 ²	33	66	99	122
Digital Inputs Per Board Set						
Description	AC	DC	1 Board Set	2 Board Sets	3 Board Sets	4 Board Sets
Standard	27	11	38	76	114	152
Optional AICB	47	11	58	116	174	232

² Eight of the DC are individually programmable as either inputs or outputs. The number indicated here is the maximum if all programmed as inputs or all programmed as outputs.

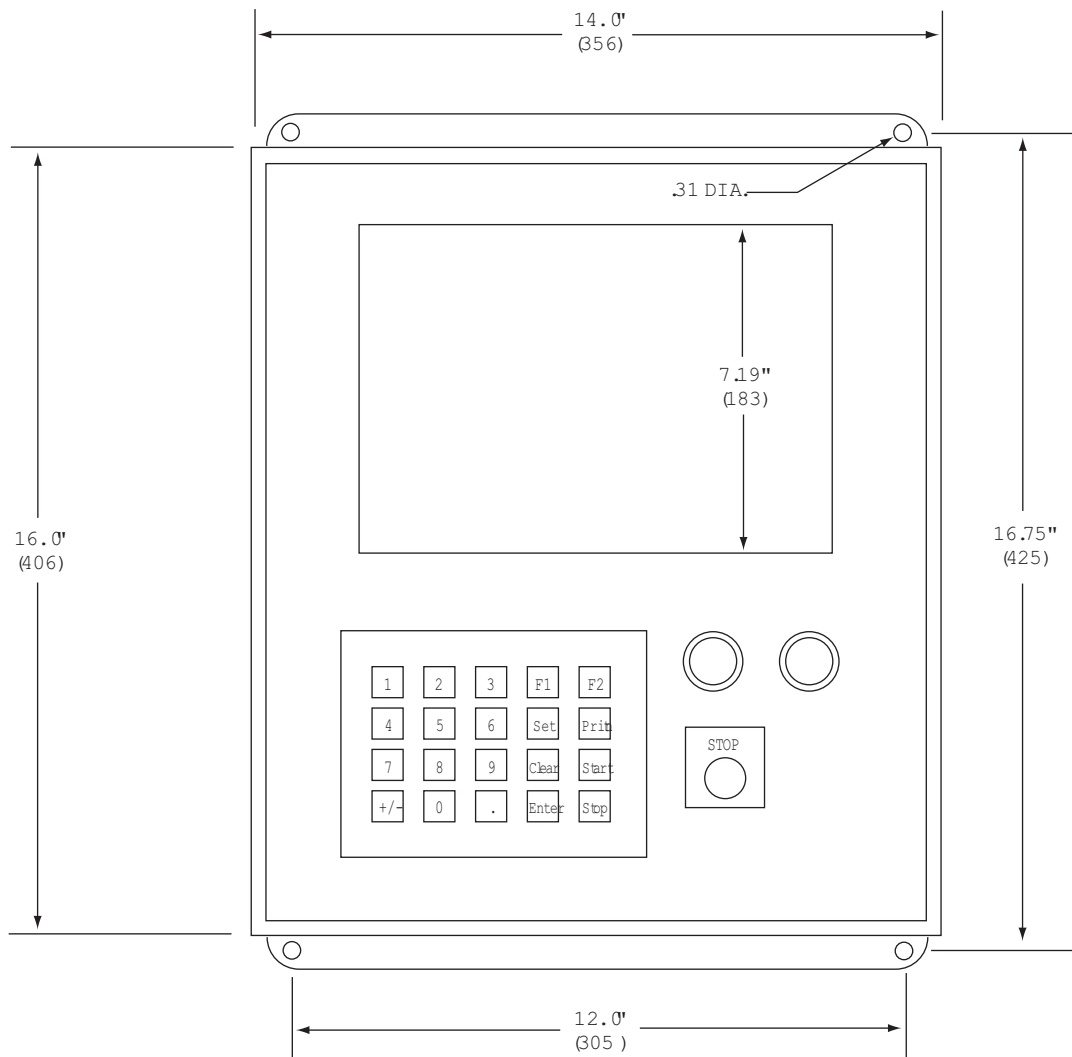

Note: Dimensions – Inches to the nearest tenth (millimetres to the nearest whole mm), each independently dimensioned from respective engineering drawings.

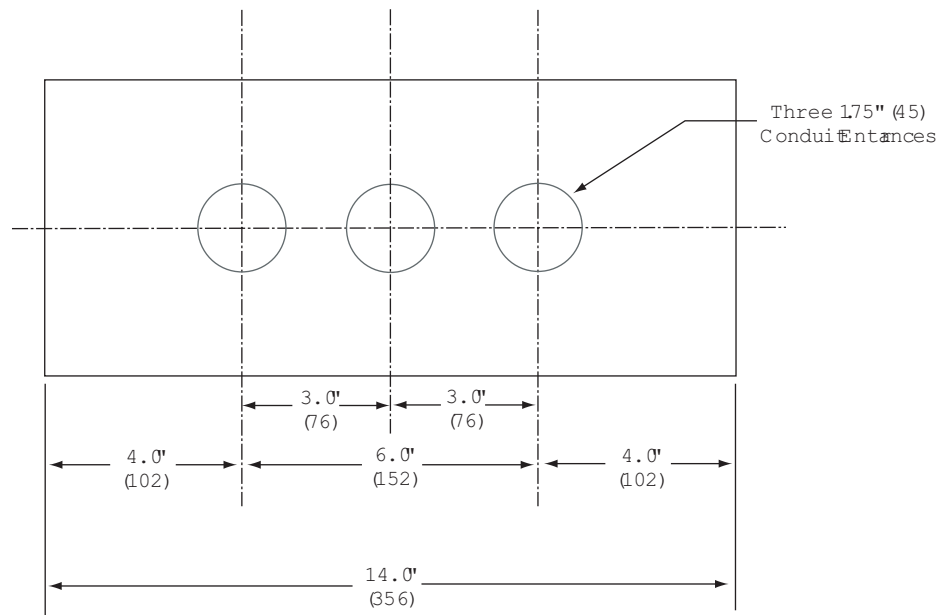

Figure 1 – Operator Interface Dimensional Outline

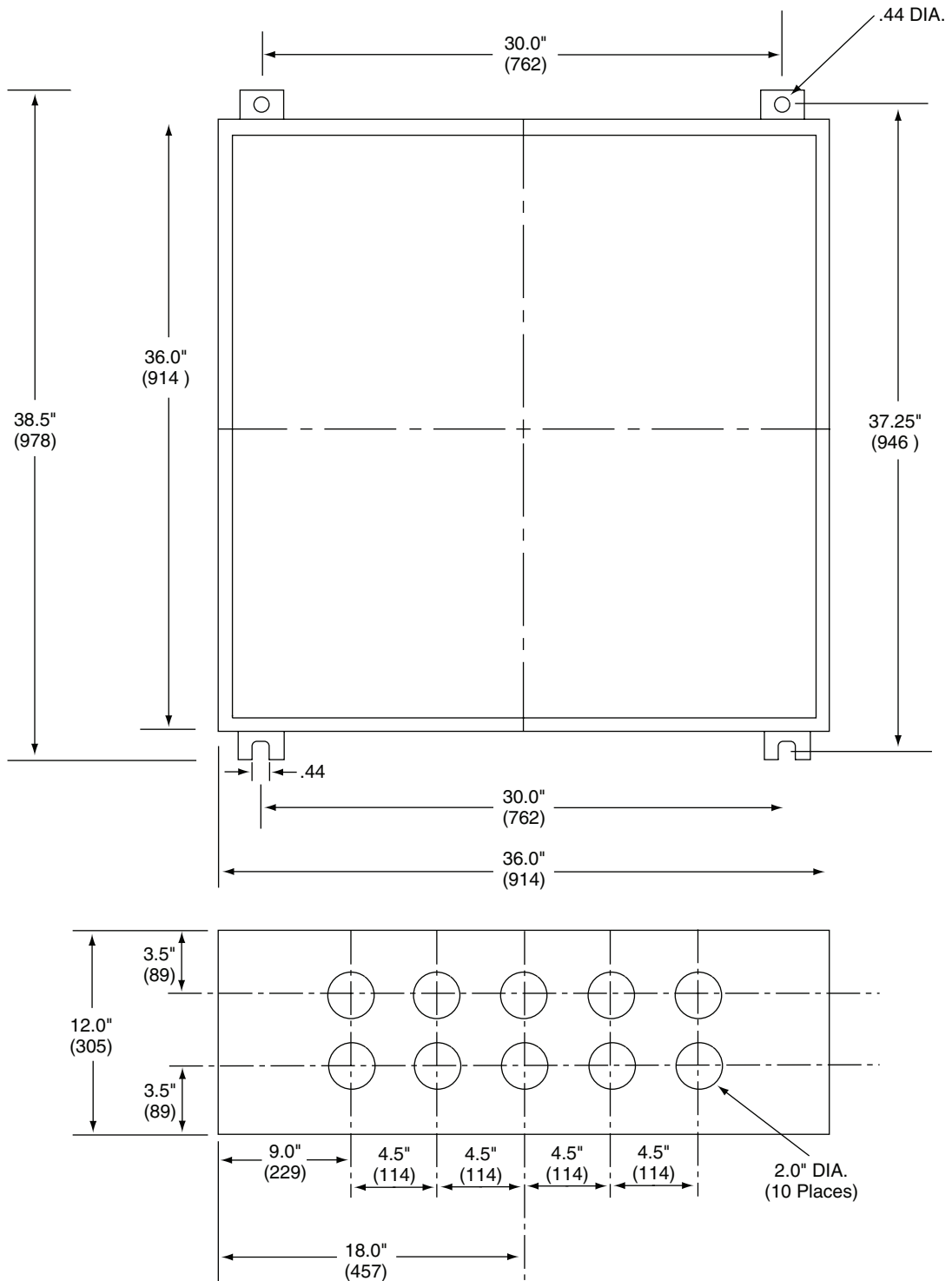

Figure 2 – Flow Controlled Unit Dimensional

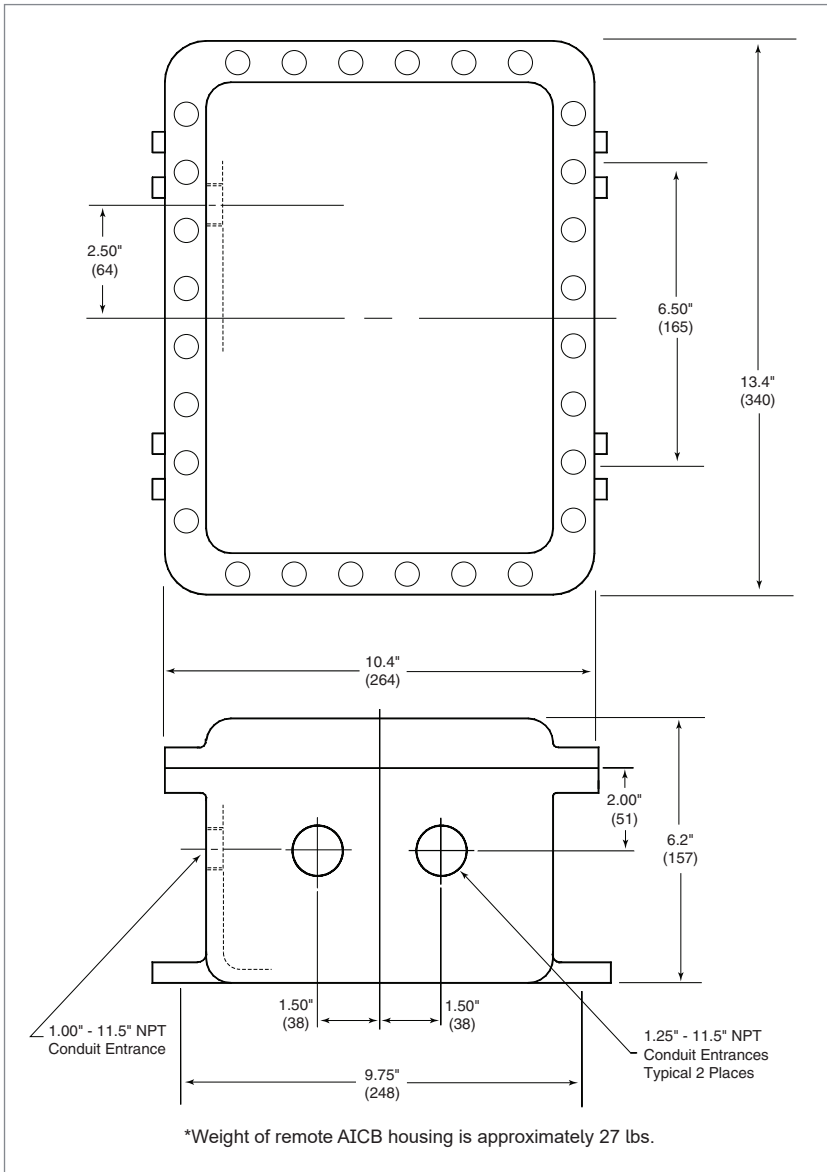

Figure 3 – Remote Housing (Optional AICB)

Revisions included in SS06039 Issue/Rev. 0.6 (2/19):

Weights & Measures added; Approvals sections updated.

The specifications contained herein are subject to change without notice and any user of said specifications should verify from the manufacturer that the specifications are currently in effect. Otherwise, the manufacturer assumes no responsibility for the use of specifications which may have been changed and are no longer in effect.